

DHS+ d x 1.5 DHS+立銑刀 (1.5倍刃長)

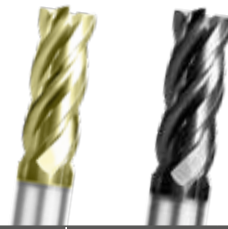

切削條件表 P148-149
Cutting Condition

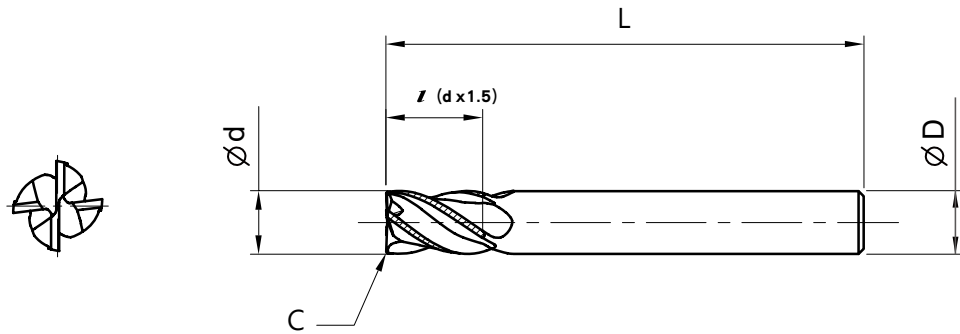

MODE	Diameter	Flute Length	Full Length	Shank Diameter	Chamfer	Coating	
型號	d 刃徑	z 刃長	L 全長	D 柄徑	C 角	ZrN-A	nACro
DHS+0304	3	4.5	50	4	0.05	.03	.08
DHS+0404	4	6.0	50	4	0.06	.03	.08
DHS+0504	5	7.5	50	6	0.08	.03	.08
DHS+0604	6	9.0	50	6	0.09	.03	.08
DHS+0804	8	12.0	60	8	0.12	.03	.08
DHS+1004	10	15.0	75	10	0.15	.03	.08
DHS+1204	12	18.0	75	12	0.18	.03	.08
DHS+1604	16	24.0	100	16	0.24	.03	.08
DHS+2004	20	30.0	100	20	0.30	.03	.08

Application 適用材質：

★ Perfect 最推薦

◎ Excellent 適合

○ Good 佳

Coating 塗層	Carbon steel, Alloy steel 炭素鋼, 合金鋼	Pre-harden steel 預硬鋼	High-hardened 高硬度鋼					Stainless steel 不鏽鋼	Titanium alloy 鈦合金	Nickel/Inconel alloy 鎳基合金	Copper alloy 銅合金, 銅	Aluminum alloy 鋁合金	Cast iron 鑄鐵
		~45HRC	~50HRC	~55HRC	~60HRC	~65HRC							
nACro	◎	◎	◎	○			○		○				◎
ZrN-A	◎	◎	○	○			○						◎

DH+ d x 2~2.5 DH+立銑刀 (2~2.5倍刃長)



切削條件表 **P148-149**
Cutting Condition

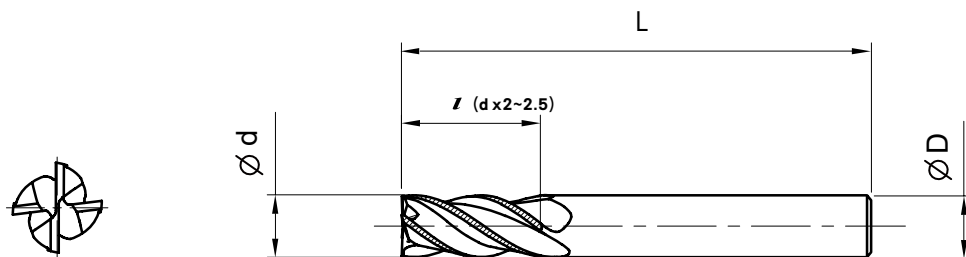

MODE	Diameter	Flute Length	Full Length	Shank Diameter	Coating	
型號	d 刃徑	L 刃長	L 全長	D 柄徑	ZrN-A	nACro
DH+0404	4	10.0	50	4	.03	.08
DH+0604	6	13.0	50	6	.03	.08
DH+0804	8	19.0	60	8	.03	.08
DH+1004	10	22.0	75	10	.03	.08
DH+1204	12	26.0	75	12	.03	.08
DH+1604	16	32.0	100	16	.03	.08
DH+2004	20	40.0	100	20	.03	.08

Application 適用材質：

★ Perfect 最推薦 ◎ Excellent 適合 ○ Good 佳

Coating 塗層	Carbon steel, Alloy steel 炭素鋼, 合金鋼	Pre-hardened steel 預硬鋼	High-hardened 高硬度鋼					Stainless steel 不鏽鋼	Titanium alloy 鈦合金	Nickel/Inconel alloy 鎳基合金	Copper alloy 銅合金, 銅	Aluminum alloy 鋁合金	Cast iron 鑄鐵
		~45HRC	~50HRC	~55HRC	~60HRC	~65HRC							
nACro	◎	◎	◎	○			○		○			◎	
ZrN-A	◎	◎	○	○			○					◎	