

BT



BT

BT是日本規範7/24圓錐的代號。

始於1969年的MAS403規範,稱為MAS403-BT。

是最早的ATC(Automatic Tool Changer)7/24圓錐規範

1998年日本工公佈JIS B 6339:1998規範代替了MAS403規範

2007年ISO7388-2:2007是7/24 BT外圓錐新規範

BT**刀桿命名為ISO**J

BT**AD刀桿內帶中心貫穿冷卻孔命名為ISO**JD

BT**B刀桿法蘭端面帶冷卻孔命名為ISO**JF

BT**AD/B刀桿將兩種內冷卻方式整合命名為ISO**JD/F

BT is the norm of 7/24 taper from Japan.

It started from the norm MAS403 in 1969, called MAS403-BT

It was the first norm of 7/24 taper with ATC (Automatic Tool Changer)

In 1998, Japan published norm JIS B 6339:1998 to replace MAS403-BT

In 2007, ISO published ISO7388-2:2007 as new norm for 7/24 BT taper toolholder

BT** was named as ISO**J

BT**AD with coolant through center was named as ISO**JD

BT**B with coolant through flange was named as ISO**JF

BT**AD/B with two type coolant through was named as ISO**JD/F

CLAMPING FORCE	BT30	BT40	BT50
	6KN	12KN	25KN

TAPER	BT30AD	BT40AD	BT50AD
	ISO30JD	ISO40JD	ISO50JD
ØD1	31.75	44.45	69.85
Ød2 H8	12.5	17	25
d7 6H	M12*P1.75	M16*P2.0	M24*P3.0
ØD5 h8	46	63	100
v +/-0.1	13.6	16.6	23.2
y +/-0.4	2	2	3
f	20	25	35
l1 +/-0.2	48.4	65.4	101.6
l2	24	30	45
l4+0.5/0.0	7	9	13
l6	6.3 -0.3/+0.0	2.6 -0.3/+0.0	35.4 -0.4/+0.0
b +/-0.2/0.0	16.1	16.1	25.7

TAPER	BT30AD/B	BT40AD/B	BT50AD/B
	ISO30JD/F	ISO40JD/F	ISO50JD/F
e1	20	27	42
Ød9	2	4	6

TAPER	BT30GAD
ØD1	31.75
Ød2 H8	12.50
d7 6H	M12*P1.75
ØD5 h8	46.00
v +/-0.1	13.60
y +/-0.4	2
f	20
l1 +/-0.2	48.40
l2	24
l4+0.5/0.0	7.0
l6	6.3 -0.3/+0.0

圓錐角度公差 // TAPER ANGLE TOLERANCE			
TAPER	#30 TAPER	#40 TAPER	#50 TAPER
AT1 (mm)	3008/+0.0013	3010/+0.0016	+0.0013/+0.0020
AT2 (mm)	3013/+0.0020	3016/+0.0025	+0.0020/+0.0032
AT3 (mm)	3020/+0.0032	3025/+0.0040	+0.0032/+0.0050

圓錐角度直線度公差 // TAPER ANGLE STRAIGHTNESS TOLERANCE			
TAPER	#30 TAPER	#40 TAPER	#50 TAPER
	0.002	0.002	0.003

圓錐圓度公差 // TAPER ROUNDNESS TOLERANCE			
TAPER	#30 TAPER	#40 TAPER	#50 TAPER
	0.001	0.001	0.002

7/24圓錐刀桿精度達到0.002mm的鼻端圓度

AT2的錐體角度公差是必須的

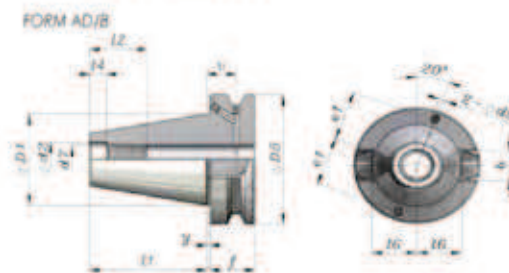
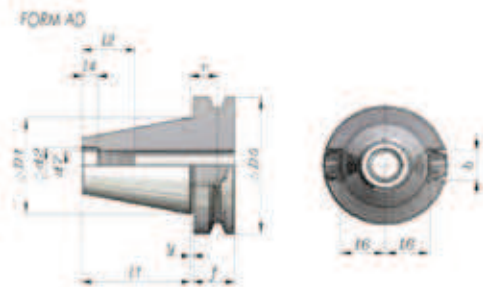

BT30G FORM AD:
BT30 FORM AD W/O DRIVE KEY SLOTS

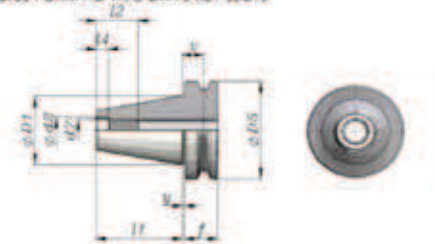

To achieve 0.002mm runout of T.I.R 7/24 taper

AT2 taper angle tolerance is a "MUST"

Shrink fit chucks

熱膨脹燒結刀桿

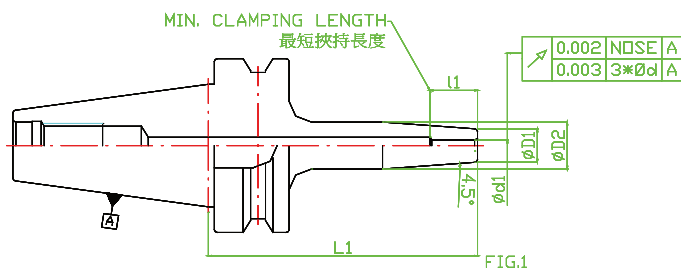

動平衡G2.5/25,000RPM可以另外施作 // BALANCE TO G2.5/25,000RPM IS AVAILABLE ON REQUEST

STOCK	CODE	FIG.	L1	L2	ØD1	ØD2	ØD3	Ød	I1-min. 最短夾持長度 Min. Clamping Length	I2-max. 最長夾持長度 Max. Clamping Length	止動螺絲 (M) Screw Page 153	重量 (KG) Weight
◎	BT30AD-EZ03-080	1	80	-	12	17	-	3	15	-	-	0.60
◎	BT30AD-EZ04-080	1	80	-	12	17	-	4	17	-	-	0.60
◎	BT30AD-EZ05-080	1	80	-	12	17	-	5	17	-	-	0.60

STOCK ◎=標準在庫品 // STOCK ◎=regular stock | STOCK ○=少量在庫品
STOCK ○=few stock | STOCK 無標示=接單生產品 // STOCK BLANK=on request

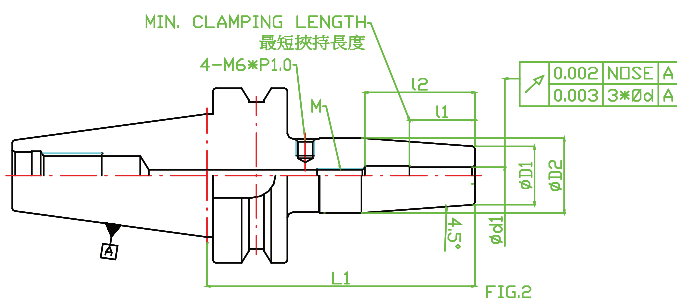

動平衡G2.5/25,000RPM可以另外施作 // BALANCE TO G2.5/25,000RPM IS AVAILABLE ON REQUEST

STOCK	CODE	FIG.	L1	L2	ØD1	ØD2	ØD3	Ød	I1-min. 最短夾持長度 Min. Clamping Length	I2-max. 最長夾持長度 Max. Clamping Length	止動螺絲 (M) Screw Page 153	重量 (KG) Weight
◎	BT30AD-EZ06-080	2	80	-	21	27	-	6	23	37	M5*P0.8	0.70
◎	BT30AD-EZ08-080	2	80	-	21	27	-	8	27	37	M6*P1.0	0.70
◎	BT30AD-EZ10-080	2	80	-	24	32	-	10	32	42	M8*P1.0	0.80
◎	BT30AD-EZ12-080	2	80	-	24	32	-	12	37	48	M10*P1.0	0.80
◎	BT30AD-EZ14-080	2	80	-	27	34	-	14	37	48	M10*P1.0	0.80
◎	BT30AD-EZ16-080	2	80	-	27	34	-	16	40	51	M12*P1.0	0.80
◎	BT30AD-EZ18-090	2	90	-	33	42	-	18	40	51	M12*P1.0	1.00
◎	BT30AD-EZ20-090	2	90	-	33	42	-	20	42	53	M16*P1.0	1.00

產品FIG.2出貨附件為長度調整螺絲BK-EZ-Mxx*1pc // PRODUCTS IN FIG.2 EQUIP WITH BACK UP SCREW BK-EZ-Mxx*1PC
STOCK ◎=標準在庫品 // STOCK ◎=regular stock | STOCK ○=少量在庫品 // STOCK ○=few stock | STOCK 無標示=接單生產品 //
STOCK BLANK=on request

BT-EZ

Shrink fit chucks

熱膨脹燒結刀桿

60

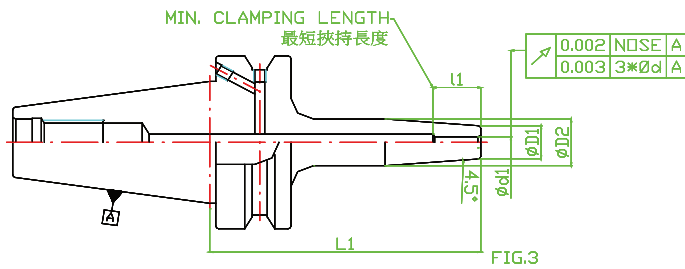

動平衡G2.5/25,000RPM可以另外施作 // BALANCE TO G2.5/25,000RPM IS AVAILABLE ON REQUEST

STOCK	CODE	FIG.	L1	L2	ØD1	ØD2	ØD3	Ød	l1-min. 最短夾持長度 Min. Clamping Length	l2-max. 最長夾持長度 Max. Clamping Length	止動螺絲 (M) Screw Page 153	重量 (KG) Weight
◎	BT40AD/B-EZ03-090	3	90	-	12	17	-	3	15	-	-	1.10
◎	BT40AD/B-EZ04-090	3	90	-	12	17	-	4	17	-	-	1.10
◎	BT40AD/B-EZ05-090	3	90	-	12	17	-	5	17	-	-	1.10

STOCK ◎=標準在庫品 // STOCK ◎=regular stock | STOCK ○=少量在庫品 // STOCK ○=few stock | STOCK 無標示=接單生產品 // STOCK BLANK=on request

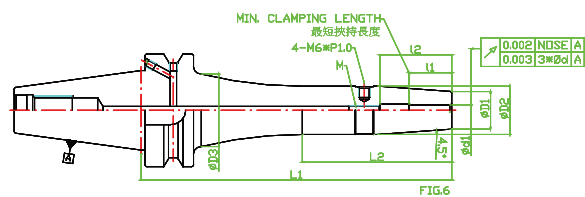
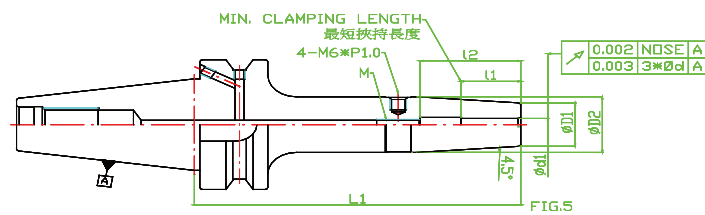
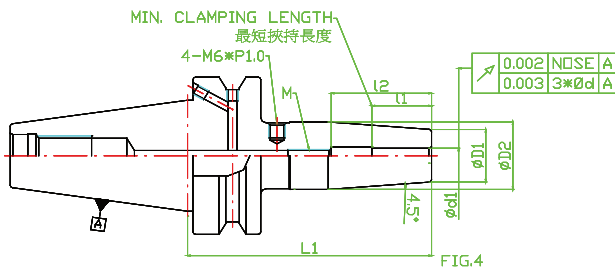

■ Shrink fit chucks

● 熱膨脹燒結刀桿

動平衡G2.5/25,000RPM可以另外施作 // BALANCE TO G2.5/25,000RPM IS AVAILABLE ON REQUEST

STOCK	CODE	FIG.	L1	L2	ØD1	ØD2	ØD3	Ød	I1-min. 最短夾持長度 Min. Clamping Length	I2-max. 最長夾持長度 Max. Clamping Length	止動螺絲 (M) Screw Page 153	重量 (KG) Weight
◎	BT40AD/B-EZ06-090	4	90	-	21	27	-	6	23	37	M5*P0.8	1.20
○	BT40AD/B-EZ06-120	5	120	-	21	27	-	6	23	37	M5*P0.8	1.50
	BT40AD/B-EZ06-160	6	160	78	21	27	41	6	23	37	M5*P0.8	1.80
	BT40AD/B-EZ06-200	6	200	118	21	27	41	6	23	37	M5*P0.8	2.20
◎	BT40AD/B-EZ08-090	4	90	-	21	27	-	8	27	37	M6*P1.0	1.20
○	BT40AD/B-EZ08-120	5	120	-	21	27	-	8	27	37	M6*P1.0	1.50
	BT40AD/B-EZ08-160	6	160	78	21	27	41	8	27	37	M6*P1.0	1.80
	BT40AD/B-EZ08-200	6	200	118	21	27	41	8	27	37	M6*P1.0	2.20
◎	BT40AD/B-EZ10-090	4	90	-	24	32	-	10	32	42	M8*P1.0	1.30
○	BT40AD/B-EZ10-120	5	120	-	24	32	-	10	32	42	M8*P1.0	1.60
	BT40AD/B-EZ10-160	6	160	78	24	32	40	10	32	42	M8*P1.0	1.90
	BT40AD/B-EZ10-200	6	200	118	24	32	40	10	32	42	M8*P1.0	2.30
◎	BT40AD/B-EZ12-090	4	90	-	24	32	-	12	37	48	M10*P1.0	1.30
○	BT40AD/B-EZ12-120	5	120	-	24	32	-	12	37	48	M10*P1.0	1.60
	BT40AD/B-EZ12-160	6	160	78	24	32	40	12	37	48	M10*P1.0	1.90
	BT40AD/B-EZ12-200	6	200	118	24	32	40	12	37	48	M10*P1.0	2.30
◎	BT40AD/B-EZ14-090	4	90	-	27	34	-	14	37	48	M10*P1.0	1.30
○	BT40AD/B-EZ14-120	5	120	-	27	34	-	14	37	48	M10*P1.0	1.60
	BT40AD/B-EZ14-160	6	160	78	27	34	42	14	37	48	M10*P1.0	1.90
	BT40AD/B-EZ14-200	6	200	118	27	34	42	14	37	48	M10*P1.0	2.30
◎	BT40AD/B-EZ16-090	4	90	-	27	34	-	16	40	51	M12*P1.0	1.30
○	BT40AD/B-EZ16-120	5	120	-	27	34	-	16	40	51	M12*P1.0	1.60
	BT40AD/B-EZ16-160	6	160	78	27	34	42	16	40	51	M12*P1.0	1.90
	BT40AD/B-EZ16-200	6	200	118	27	34	42	16	40	51	M12*P1.0	2.30
◎	BT40AD/B-EZ18-090	4	90	-	33	42	-	18	40	51	M12*P1.0	1.40
○	BT40AD/B-EZ18-120	5	120	-	33	42	-	18	40	51	M12*P1.0	1.80
	BT40AD/B-EZ18-160	5	160	-	33	42	-	18	40	51	M12*P1.0	2.10
	BT40AD/B-EZ18-200	5	200	-	33	42	-	18	40	51	M12*P1.0	2.40
◎	BT40AD/B-EZ20-090	4	90	-	33	42	-	20	40	51	M16*P1.0	1.40
○	BT40AD/B-EZ20-120	5	120	-	33	42	-	20	42	53	M16*P1.0	1.80
	BT40AD/B-EZ20-160	5	160	-	33	42	-	20	42	53	M16*P1.0	2.10
	BT40AD/B-EZ20-200	5	200	-	33	42	-	20	42	53	M16*P1.0	2.40
◎	BT40AD/B-EZ25-100	4	100	-	44	53	-	25	48	59	M16*P1.0	2.00
○	BT40AD/B-EZ25-120	5	120	-	44	53	-	25	48	59	M16*P1.0	2.30
	BT40AD/B-EZ25-160	5	160	-	44	53	-	25	48	59	M16*P1.0	2.60
	BT40AD/B-EZ25-200	5	200	-	44	53	-	25	48	59	M16*P1.0	3.00
◎	BT40AD/B-EZ32-100	4	100	-	44	53	-	32	52	63	M16*P1.0	2.00
○	BT40AD/B-EZ32-120	5	120	-	44	53	-	32	52	63	M16*P1.0	2.30
	BT40AD/B-EZ32-160	5	160	-	44	53	-	32	52	63	M16*P1.0	2.60
	BT40AD/B-EZ32-200	5	200	-	44	53	-	32	52	63	M16*P1.0	3.00

產品FIG.4,5 & 6出貨附件為長度調整螺絲BK-EZ-Mxx*1pc // PRODUCTS IN FIG.4, 5 & 6 EQUIP WITH BACK UP SCREW BK-EZ-Mxx*1PC
 STOCK ◎=標準在庫品 // STOCK ◎=regular stock | STOCK ○=少量在庫品 // STOCK ○=few stock | STOCK無標示=接單生產品 // STOCK
 BLANK=on request

BT-EZ

Shrink fit chucks

熱膨脹燒結刀桿

62

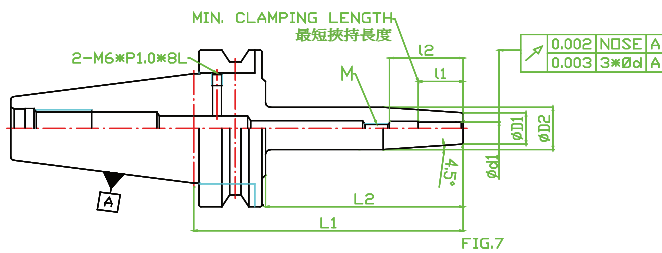

FIG.7

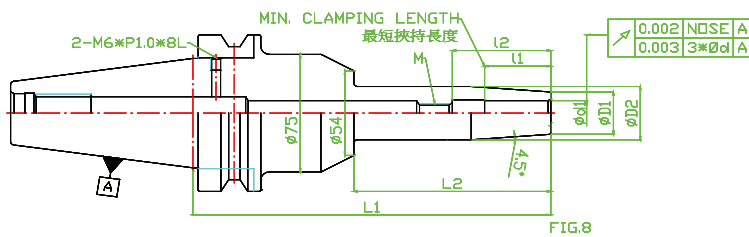

FIG.8



動平衡G2.5/25,000RPM可以另外施作 // BALANCE TO G2.5/25,000RPM IS AVAILABLE ON REQUEST

STOCK	CODE	FIG.	L1	L2	ØD1	ØD2	ØD3	Ød	l1-min. 最短夾持長度 Min. Clamping Length	l2-max. 最長夾持長度 Max. Clamping Length	止動螺絲 (M) Screw Page 153	重量 (KG) Weight
○	BT50AD-EZX06-105	7	105	65	21	27	-	6	23	37	M5*P0.8	3.80
○	BT50AD-EZX06-150	7	150	110	21	27	-	6	23	37	M5*P0.8	4.10
○	BT50AD-EZX06-200	8	200	110	21	27	-	6	23	37	M5*P0.8	5.60
○	BT50AD-EZX08-105	7	105	65	21	27	-	8	27	37	M6*P1.0	3.80
○	BT50AD-EZX08-150	7	150	110	21	27	-	8	27	37	M6*P1.0	4.10
○	BT50AD-EZX08-200	8	200	110	21	27	-	8	27	37	M6*P1.0	5.60
○	BT50AD-EZX10-105	7	105	65	24	32	-	10	32	42	M8*P1.25	3.90
○	BT50AD-EZX10-150	7	150	110	24	32	-	10	32	42	M8*P1.25	4.20
○	BT50AD-EZX10-200	8	200	110	24	32	-	10	32	42	M8*P1.25	5.70
○	BT50AD-EZX12-105	7	105	65	24	32	-	12	37	48	M10*P1.5	3.90
○	BT50AD-EZX12-150	7	150	110	24	32	-	12	37	48	M10*P1.5	4.20
○	BT50AD-EZX12-200	8	200	110	24	32	-	12	37	48	M10*P1.5	5.80
○	BT50AD-EZX14-105	7	105	65	27	37	-	14	37	48	M10*P1.5	3.90
○	BT50AD-EZX14-150	7	150	110	27	37	-	14	37	48	M10*P1.5	4.20
○	BT50AD-EZX14-200	8	200	110	27	37	-	14	37	48	M10*P1.5	5.80
○	BT50AD-EZX16-105	7	105	65	27	34	-	16	40	51	M12*P1.75	3.90
○	BT50AD-EZX16-150	7	150	110	27	34	-	16	40	51	M12*P1.75	4.20
○	BT50AD-EZX16-200	8	200	110	27	34	-	16	40	51	M12*P1.75	5.80
○	BT50AD-EZX18-105	7	105	65	33	42	-	18	40	51	M12*P1.75	4.00
○	BT50AD-EZX18-150	7	150	110	33	42	-	18	40	51	M12*P1.75	4.30
○	BT50AD-EZX18-200	8	200	110	33	42	-	18	40	51	M12*P1.75	5.90
○	BT50AD-EZX20-105	7	105	65	33	42	-	20	42	53	M16*P2.0	4.00
○	BT50AD-EZX20-150	7	150	110	33	42	-	20	42	53	M16*P2.0	4.30
○	BT50AD-EZX20-200	8	200	110	33	42	-	20	42	53	M16*P2.0	5.90

產品FIG.7 & 8出貨附件為長度調整螺絲BK-EZ-Mxx*1pc // PRODUCTS IN FIG.7 & 8 EQUIP WITH BACK UP SCREW BK-EZ-Mxx*1PC
 STOCK ◎=標準在庫品 // STOCK ◎=regular stock | STOCK ○=少量在庫品 // STOCK ○=few stock | STOCK無標示=接單生產品 // STOCK
 BLANK=on request

Shrink fit chucks

熱膨脹燒結刀桿

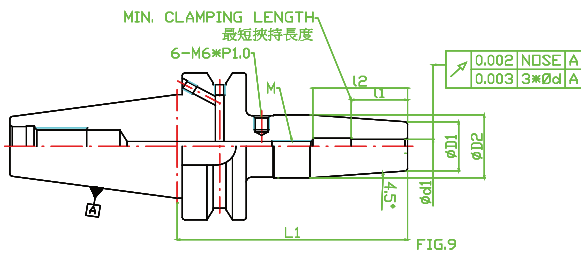

FIG.9

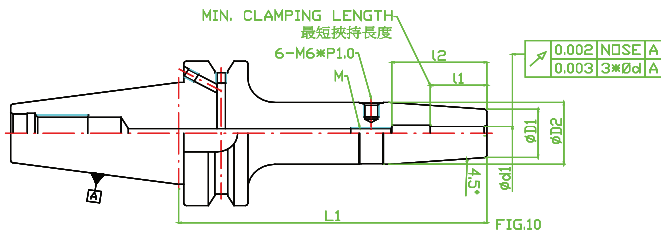

FIG.10

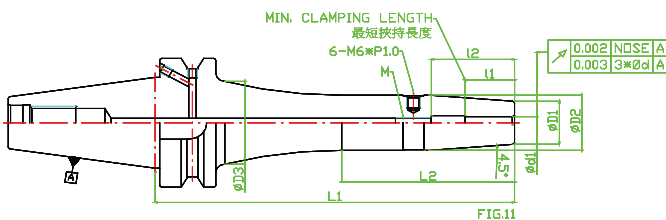

FIG.11



動平衡G2.5/25,000RPM可以另外施作 // BALANCE TO G2.5/25,000RPM IS AVAILABLE ON REQUEST

STOCK	CODE	FIG.	L1	L2	ØD1	ØD2	ØD3	Ød	l1-min. 最短夾持長度 Min. Clamping Length	l2-max. 最長夾持長度 Max. Clamping Length	止動螺絲 (M) Screw Page 153	重量 (KG) Weight
	BT50AD/B-EZ25-100	9	100	-	44	53	-	25	48	59	M16*P1.0	4.40
	BT50AD/B-EZ25-130	10	130	-	44	53	-	25	48	59	M16*P1.0	4.80
	BT50AD/B-EZ25-160	11	160	75	44	53	59	25	48	59	M16*P1.0	5.50
	BT50AD/B-EZ25-200	11	200	110	44	53	60	25	48	59	M16*P1.0	6.00
	BT50AD/B-EZ32-100	9	100	-	44	53	-	32	52	63	M16*P1.0	4.40
	BT50AD/B-EZ32-130	10	130	-	44	53	-	32	52	63	M16*P1.0	4.80
	BT50AD/B-EZ32-160	11	160	75	44	53	59	32	52	63	M16*P1.0	5.00
	BT50AD/B-EZ32-200	11	200	110	44	53	60	32	52	63	M16*P1.0	6.00

產品FIG.9, 10 & 11出貨附件為長度調整螺絲BK-EZ-Mxx*1pc // PRODUCTS IN FIG.9, 10 & 11 EQUIP WITH BACK UP SCREW BK-EZ-Mxx*1PC
 STOCK ◎=標準在庫品 // STOCK ◎=regular stock | STOCK ○=少量在庫品 // STOCK ○=few stock | STOCK 無標示=接單生產品 // STOCK
 BLANK=on request

BT-EZKK

Shrink fit chucks with coolant through nose

鼻端噴水熱膨脹燒結刀桿

64

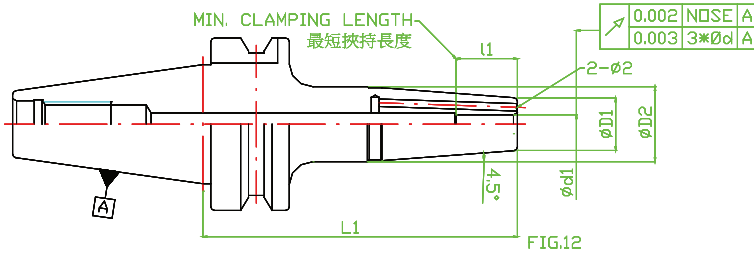

動平衡G2.5/25,000RPM可以另外施作 // BALANCE TO G2.5/25,000RPM IS AVAILABLE ON REQUEST

STOCK	CODE	FIG.	L1	L2	ØD1	ØD2	ØD3	Ød	I1-min. 最短夾持長度 Min. Clamping Length	I2-max. 最長夾持長度 Max. Clamping Length	止動螺絲 (M) Screw Page 153	重量 (KG) Weight
◎	BT30AD-EZ03-080KK	12	80	-	14	20	-	3	15	-	-	0.60
○	BT30AD-EZ03-120KK	12	120	-	14	20	-	3	15	-	-	0.90
◎	BT30AD-EZ04-080KK	12	80	-	14	20	-	4	17	-	-	0.60
○	BT30AD-EZ04-120KK	12	120	-	14	20	-	4	17	-	-	0.90
◎	BT30AD-EZ05-080KK	12	80	-	14	20	-	5	17	-	-	0.60
○	BT30AD-EZ05-120KK	12	120	-	14	20	-	5	17	-	-	0.90

STOCK ◎=標準在庫品 // STOCK ○=regular stock | STOCK ○=少量在庫品 // STOCK ○=few stock | STOCK無標示=接單生產品 // STOCK BLANK=on request

動平衡G2.5/25,000RPM可以另外施作 // BALANCE TO G2.5/25,000RPM IS AVAILABLE ON REQUEST

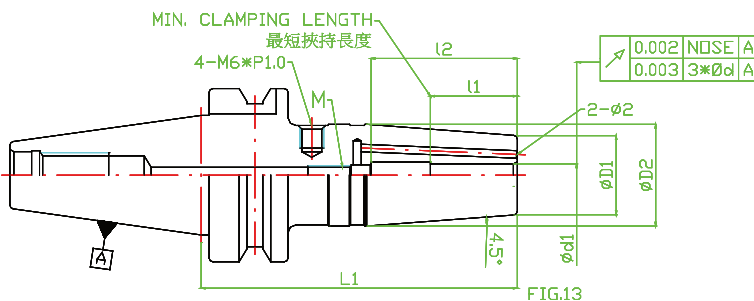

動平衡G2.5/25,000RPM可以另外施作 // BALANCE TO G2.5/25,000RPM IS AVAILABLE ON REQUEST

STOCK	CODE	FIG.	L1	L2	ØD1	ØD2	ØD3	Ød	I1-min. 最短夾持長度 Min. Clamping Length	I2-max. 最長夾持長度 Max. Clamping Length	止動螺絲 (M) Screw Page 153	重量 (KG) Weight
◎	BT30AD-EZ06-080KK	13	80	-	21	27	-	6	23	37	M5*P0.8	0.70
○	BT30AD-EZ06-120KK	13	120	-	21	27	-	6	23	37	M5*P0.8	1.00
◎	BT30AD-EZ08-080KK	13	80	-	21	27	-	8	27	37	M6*P1.0	0.70
○	BT30AD-EZ08-120KK	13	120	-	21	27	-	8	27	37	M6*P1.0	1.00
◎	BT30AD-EZ10-080KK	13	80	-	24	32	-	10	32	42	M8*P1.0	0.80
○	BT30AD-EZ10-120KK	13	120	-	24	32	-	10	32	42	M8*P1.0	1.10
◎	BT30AD-EZ12-080KK	13	80	-	24	32	-	12	37	48	M10*P1.0	0.80
○	BT30AD-EZ12-120KK	13	120	-	24	32	-	12	37	48	M10*P1.0	1.10
◎	BT30AD-EZ14-080KK	13	80	-	27	34	-	14	37	48	M10*P1.0	0.80
○	BT30AD-EZ14-120KK	13	120	-	27	34	-	14	37	48	M10*P1.0	1.10
◎	BT30AD-EZ16-080KK	13	80	-	27	34	-	16	40	51	M12*P1.0	0.80
○	BT30AD-EZ16-120KK	13	120	-	27	34	-	16	40	51	M12*P1.0	1.10
◎	BT30AD-EZ18-090KK	13	80	-	33	42	-	18	40	51	M12*P1.0	0.90
○	BT30AD-EZ18-120KK	13	120	-	33	42	-	18	40	51	M12*P1.0	1.20
◎	BT30AD-EZ20-090KK	13	80	-	33	42	-	20	42	53	M16*P1.0	0.90
○	BT30AD-EZ20-120KK	13	120	-	33	42	-	20	42	53	M16*P1.0	1.20

產品FIG.13出貨附件為長度調整螺絲BK-EZKK-Mxx*1pc // PRODUCTS IN FIG.13 EQUIP WITH BACK UP SCREW BK-EZKK-Mxx*1PC

產品FIG.13出貨附件為止水螺絲M3*P0.5-4L*2pc // PRODUCTS IN FIG.13 EQUIP WITH SEAL SCREW M3*P0.5-4L*2PCS

STOCK ◎=標準在庫品 // STOCK ○=regular stock | STOCK ○=少量在庫品 // STOCK ○=few stock | STOCK無標示=接單生產品 // STOCK BLANK=on request

Shrink fit chucks with coolant through nose

鼻端噴水熱膨脹燒結刀桿

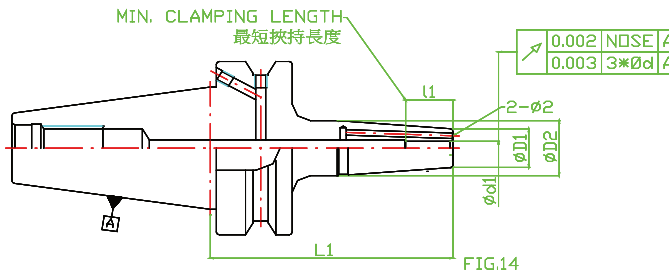

動平衡G2.5/25,000RPM可以另外施作 // BALANCE TO G2.5/25,000RPM IS AVAILABLE ON REQUEST

STOCK	CODE	FIG.	L1	L2	ØD1	ØD2	ØD3	Ød	I1-min. 最短夾持長度 Min. Clamping Length	I2-max. 最長夾持長度 Max. Clamping Length	止動螺絲 (M) Screw Page 153	重量 (KG) Weight
◎	BT40AD/B-EZ03-090KK	14	90	-	14	20	-	3	15	-	-	1.10
○	BT40AD/B-EZ03-120KK	14	120	-	14	20	-	3	15	-	-	1.40
◎	BT40AD/B-EZ04-090KK	14	90	-	14	20	-	4	17	-	-	1.10
○	BT40AD/B-EZ04-120KK	14	120	-	14	20	-	4	17	-	-	1.40
◎	BT40AD/B-EZ05-090KK	14	90	-	14	20	-	5	17	-	-	1.10
○	BT40AD/B-EZ05-120KK	14	120	-	14	20	-	5	17	-	-	1.40

STOCK ◎=標準在庫品 // STOCK ○=regular stock | STOCK ◎=少量在庫品 // STOCK ○=few stock | STOCK無標示=接單生產品 // STOCK BLANK=on request

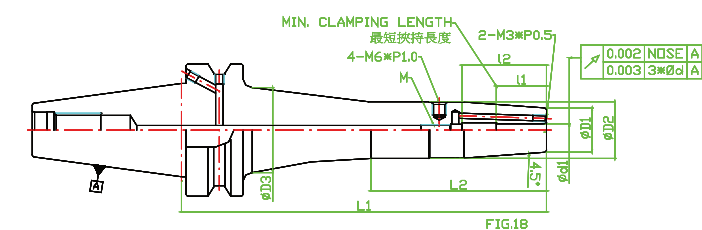
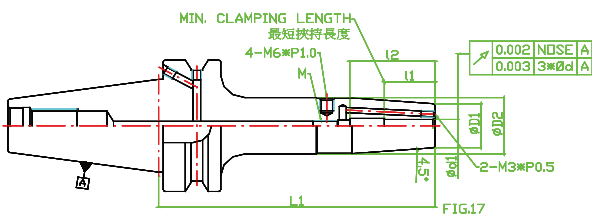
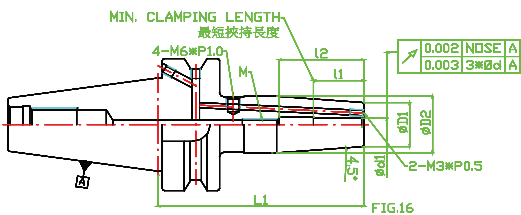
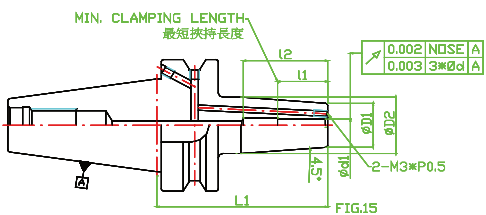

BT-EZKK

Shrink fit chucks with coolant through nose

鼻端噴水熱膨脹燒結刀桿

動平衡G2.5/25,000RPM可以另外施作 // BALANCE TO G2.5/25,000RPM IS AVAILABLE ON REQUEST

STOCK	CODE	FIG.	L1	L2	ØD1	ØD2	ØD3	Ød	I1-min. 最短夾持長度 Min. Clamping Length	I2-max. 最長夾持長度 Max. Clamping Length	止動螺絲 (M) Screw Page 153	重量 (KG) Weight
	BT40AD/B-EZ06-075KK	15	75	-	21	27	-	6	23	-	-	1.10
◎	BT40AD/B-EZ06-090KK	16	90	-	21	27	-	6	23	37	M5*P0.8	1.20
○	BT40AD/B-EZ06-120KK	17	120	-	21	27	-	6	23	37	M5*P0.8	1.50
○	BT40AD/B-EZ06-160KK	18	160	41	21	27	77	6	23	37	M5*P0.8	1.80
○	BT40AD/B-EZ06-200KK	18	200	41	21	27	117	6	23	37	M5*P0.8	2.20
	BT40AD/B-EZ08-075KK	15	75	-	21	27	-	8	27	-	-	1.10
◎	BT40AD/B-EZ08-090KK	16	90	-	21	27	-	8	27	37	M6*P1.0	1.20
○	BT40AD/B-EZ08-120KK	17	120	-	21	27	-	8	27	37	M6*P1.0	1.50
○	BT40AD/B-EZ08-160KK	18	160	41	21	27	78	8	27	37	M6*P1.0	1.80
○	BT40AD/B-EZ08-200KK	18	200	41	21	27	118	8	27	37	M6*P1.0	2.20
	BT40AD/B-EZ10-075KK	15	75	-	24	32	-	10	32	-	-	1.20
◎	BT40AD/B-EZ10-090KK	16	90	-	24	32	-	10	32	42	M8*P1.0	1.30
○	BT40AD/B-EZ10-120KK	17	120	-	24	32	-	10	32	42	M8*P1.0	1.60
○	BT40AD/B-EZ10-160KK	18	160	40	24	32	78	10	32	42	M8*P1.0	1.90
○	BT40AD/B-EZ10-200KK	18	200	40	24	32	118	10	32	42	M8*P1.0	2.30
	BT40AD/B-EZ12-075KK	15	75	-	24	32	-	12	37	-	-	1.20
◎	BT40AD/B-EZ12-090KK	16	90	-	24	32	-	12	37	48	M10*P1.0	1.30
○	BT40AD/B-EZ12-120KK	17	120	-	24	32	-	12	37	48	M10*P1.0	1.60
○	BT40AD/B-EZ12-160KK	18	160	40	24	32	78	12	37	48	M10*P1.0	1.90
○	BT40AD/B-EZ12-200KK	18	200	40	24	32	118	12	37	48	M10*P1.0	2.30
	BT40AD/B-EZ14-075KK	15	75	-	27	34	-	14	37	-	-	1.20
◎	BT40AD/B-EZ14-090KK	16	90	-	27	34	-	14	37	48	M10*P1.0	1.30
○	BT40AD/B-EZ14-120KK	17	120	-	27	34	-	14	37	48	M10*P1.0	1.60
○	BT40AD/B-EZ14-160KK	18	160	42	27	34	78	14	37	48	M10*P1.0	1.90
	BT40AD/B-EZ14-200KK	18	200	42	27	34	118	14	37	48	M10*P1.0	2.30
	BT40AD/B-EZ16-075KK	15	75	-	27	34	-	16	40	-	-	1.20
◎	BT40AD/B-EZ16-090KK	16	90	-	27	34	-	16	40	51	M12*P1.0	1.30
○	BT40AD/B-EZ16-120KK	17	120	-	27	34	-	16	40	51	M12*P1.0	1.60
○	BT40AD/B-EZ16-160KK	18	160	42	27	34	78	16	40	51	M12*P1.0	1.90
	BT40AD/B-EZ16-200KK	18	200	42	27	34	118	16	40	51	M12*P1.0	2.30
	BT40AD/B-EZ18-075KK	15	75	-	33	42	-	18	40	-	-	1.30
◎	BT40AD/B-EZ18-090KK	16	90	-	33	42	-	18	40	51	M12*P1.0	1.40
○	BT40AD/B-EZ18-120KK	17	120	-	33	42	-	18	40	51	M12*P1.0	1.70
	BT40AD/B-EZ18-160KK	17	160	-	33	42	-	18	40	51	M12*P1.0	2.00
	BT40AD/B-EZ18-200KK	17	200	-	33	42	-	18	40	51	M12*P1.0	2.40
	BT40AD/B-EZ20-075KK	15	75	-	33	42	-	20	40	-	-	1.30
◎	BT40AD/B-EZ20-090KK	16	90	-	33	42	-	20	42	53	M16*P1.0	1.40
○	BT40AD/B-EZ20-120KK	17	120	-	33	42	-	20	42	53	M16*P1.0	1.70
	BT40AD/B-EZ20-160KK	17	160	-	33	42	-	20	42	53	M16*P1.0	2.00
	BT40AD/B-EZ20-200KK	17	200	-	33	42	-	20	42	53	M16*P1.0	2.40
	BT40AD/B-EZ25-075KK	15	75	-	44	53	-	25	48	-	-	1.60
◎	BT40AD/B-EZ25-100KK	16	100	-	44	53	-	25	48	59	M16*P1.0	2.00
○	BT40AD/B-EZ25-120KK	17	120	-	44	53	-	25	48	59	M16*P1.0	2.30
	BT40AD/B-EZ25-160KK	17	160	-	44	53	-	25	48	59	M16*P1.0	2.60
	BT40AD/B-EZ25-200KK	17	200	-	44	53	-	25	48	59	M16*P1.0	3.00
	BT40AD/B-EZ32-075KK	15	75	-	44	53	-	32	52	-	-	1.60
◎	BT40AD/B-EZ32-100KK	16	100	-	44	53	-	32	52	63	M16*P1.0	2.00
○	BT40AD/B-EZ32-120KK	17	120	-	44	53	-	32	52	63	M16*P1.0	2.30
	BT40AD/B-EZ32-160KK	17	160	-	44	53	-	32	52	63	M16*P1.0	2.60
	BT40AD/B-EZ32-200KK	17	200	-	44	53	-	32	52	63	M16*P1.0	3.00

產品FIG.16, 17 & 18出貨附件為長度調整螺絲BK-EZKK-Mxx*1pc // PRODUCTS IN FIG.16, 17 & 18 EQUIP WITH BACK UP SCREW BK-EZKK-Mxx*1PC

產品FIG.16, 17 & 18出貨附件為止水螺絲M3*P0.5-4L*2pc // PRODUCTS IN FIG.16, 17 & 18 EQUIP WITH SEAL SCREW M3*P0.5-4L*2PCS

STOCK ◎=標準在庫品 // STOCK ○=regular stock | STOCK ○=少量在庫品 // STOCK ○=few stock | STOCK無標示=接單生產品 // STOCK BLANK=on request

Shrink fit chucks with coolant through nose

鼻端噴水熱膨脹燒結刀桿

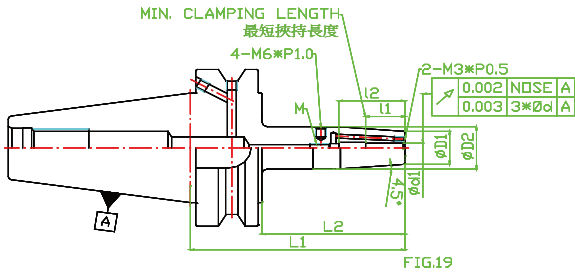

FIG.19

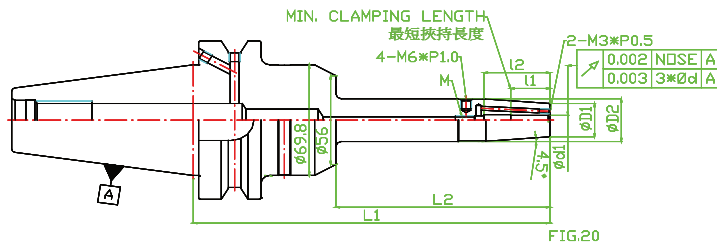

FIG.20



動平衡G2.5/25,000RPM可以另外施作 // BALANCE TO G2.5/25,000RPM IS AVAILABLE ON REQUEST

STOCK	CODE	FIG.	L1	L2	ØD1	ØD2	ØD3	Ød	I1-min. 最短夾持長度 Min. Clamping Length	I2-max. 最長夾持長度 Max. Clamping Length	止動螺絲 (M) Screw Page 153	重量 (KG) Weight
○	BT50AD/B-EZX06-100KK	19	100	60	21	27	-	6	23	37	M5*P0.8	3.80
○	BT50AD/B-EZX06-120KK	19	120	80	21	27	-	6	23	37	M5*P0.8	3.90
○	BT50AD/B-EZX06-160KK	19	160	140	21	27	-	6	23	37	M5*P0.8	4.20
	BT50AD/B-EZX06-200KK	20	200	120	21	27	-	6	23	37	M5*P0.8	5.80
○	BT50AD/B-EZX08-100KK	19	100	60	21	27	-	8	27	37	M6*P1.0	3.80
○	BT50AD/B-EZX08-120KK	19	120	80	21	27	-	8	27	37	M6*P1.0	3.90
○	BT50AD/B-EZX08-160KK	19	160	140	21	27	-	8	27	37	M6*P1.0	4.20
	BT50AD/B-EZX08-200KK	20	200	120	21	27	-	8	27	37	M6*P1.0	5.80
○	BT50AD/B-EZX10-100KK	19	100	60	24	32	-	10	32	42	M8*P1.0	3.90
○	BT50AD/B-EZX10-120KK	19	120	80	24	32	-	10	32	42	M8*P1.0	4.00
○	BT50AD/B-EZX10-160KK	19	160	140	24	32	-	10	32	42	M8*P1.0	4.30
	BT50AD/B-EZX10-200KK	20	200	120	24	32	-	10	32	42	M8*P1.0	5.90
○	BT50AD/B-EZX12-100KK	19	100	60	24	32	-	12	37	48	M10*P1.0	3.90
○	BT50AD/B-EZX12-120KK	19	120	80	24	32	-	12	37	48	M10*P1.0	4.00
○	BT50AD/B-EZX12-160KK	19	160	140	24	32	-	12	37	48	M10*P1.0	4.30
	BT50AD/B-EZX12-200KK	20	200	120	24	32	-	12	37	48	M10*P1.0	5.90
○	BT50AD/B-EZX14-100KK	19	100	60	27	34	-	14	37	48	M10*P1.0	3.90
○	BT50AD/B-EZX14-120KK	19	120	80	27	34	-	14	37	48	M10*P1.0	4.00
○	BT50AD/B-EZX14-160KK	19	160	140	27	34	-	14	37	48	M10*P1.0	4.30
	BT50AD/B-EZX14-200KK	20	200	120	27	34	-	14	37	48	M10*P1.0	5.90
○	BT50AD/B-EZX16-100KK	19	100	60	27	34	-	16	40	51	M12*P1.0	3.90
○	BT50AD/B-EZX16-120KK	19	120	80	27	34	-	16	40	51	M12*P1.0	4.00
○	BT50AD/B-EZX16-160KK	19	160	140	27	34	-	16	40	51	M12*P1.0	4.30
	BT50AD/B-EZX16-200KK	20	200	120	27	34	-	16	40	51	M12*P1.0	5.90
	BT50AD/B-EZX18-100KK	19	100	60	33	42	-	18	40	51	M12*P1.0	4.00
	BT50AD/B-EZX18-120KK	19	120	80	33	42	-	18	40	51	M12*P1.0	4.10
	BT50AD/B-EZX18-160KK	19	160	140	33	42	-	18	40	51	M12*P1.0	4.40
	BT50AD/B-EZX18-200KK	20	200	120	33	42	-	18	40	51	M12*P1.0	6.00
○	BT50AD/B-EZX20-100KK	19	100	60	33	42	-	20	42	53	M16*P1.0	4.00
○	BT50AD/B-EZX20-120KK	19	120	80	33	42	-	20	42	53	M16*P1.0	4.10
○	BT50AD/B-EZX20-160KK	19	160	140	33	42	-	20	42	53	M16*P1.0	4.40
	BT50AD/B-EZX20-200KK	20	200	120	33	42	-	20	42	53	M16*P1.0	6.00

產品FIG.19 & 20出貨附件為長度調整螺絲BK-EZKK-Mxx*1pc // PRODUCTS IN FIG.19 & 20 EQUIP WITH BACK UP SCREW BK-EZKK-Mxx*1PC

產品FIG.19 & 20出貨附件為止水螺絲M3*P0.5-4L*2pc // PRODUCTS IN FIG.19 & 20 EQUIP WITH SEAL SCREW M3*P0.5-4L*2PCS

STOCK ◎=標準在庫品 // STOCK ○=regular stock | STOCK ○=少量在庫品 // STOCK ○=few stock | STOCK無標示=接單生產 // STOCK BLANK=on request

BT-EZSU

■ SlimUltra shrink fit chucks

● 極細型熱膨脹燒結刀桿

68

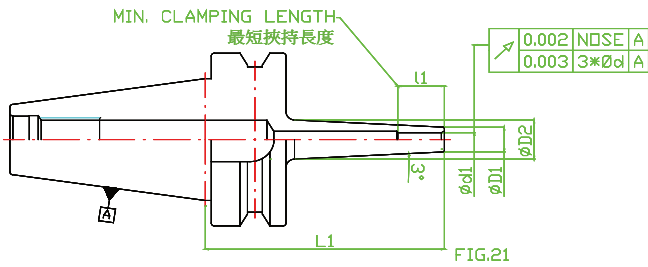

動平衡G2.5/25,000RPM可以另外施作 // BALANCE TO G2.5/25,000RPM IS AVAILABLE ON REQUEST

STOCK	CODE	FIG.	L1	L2	ØD1	ØD2	ØD3	Ød	I1-min. 最短夾持長度 Min. Clamping Length	I2-max. 最長夾持長度 Max. Clamping Length	止動螺絲 (M) Screw Page 153	重量 (KG) Weight
○	BT30AD-EZ03SU-080	21	80	-	7	13	-	3	15	-	-	0.60
○	BT30AD-EZ03SU-120	21	120	-	7	17	-	3	15	-	-	0.90
○	BT30AD-EZ04SU-080	21	80	-	8	14	-	4	17	-	-	0.60
○	BT30AD-EZ04SU-120	21	120	-	8	18	-	4	17	-	-	0.90
○	BT30AD-EZ05SU-080	21	80	-	9	15	-	5	17	-	-	0.60
○	BT30AD-EZ05SU-120	21	120	-	9	19	-	5	17	-	-	0.90

STOCK ○=標準在庫品 // STOCK ◎=regular stock | STOCK ○=少量在庫品 // STOCK ○=few stock | STOCK無標示=接單生產品 // STOCK BLANK=on request

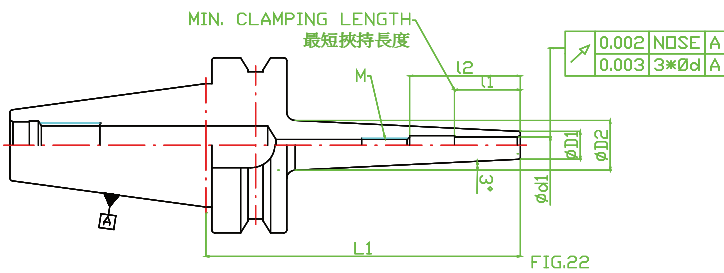

動平衡G2.5/25,000RPM可以另外施作 // BALANCE TO G2.5/25,000RPM IS AVAILABLE ON REQUEST

STOCK	CODE	FIG.	L1	L2	ØD1	ØD2	ØD3	Ød	I1-min. 最短夾持長度 Min. Clamping Length	I2-max. 最長夾持長度 Max. Clamping Length	止動螺絲 (M) Screw Page 153	重量 (KG) Weight
○	BT30AD-EZ06SU-080	22	80	-	10	16	-	6	23	37	M5*P0.8	0.70
○	BT30AD-EZ06SU-120	22	120	-	10	20	-	6	23	37	M5*P0.8	1.00
○	BT30AD-EZ08SU-080	22	80	-	12	16	-	8	27	37	M6*P1.0	0.70
○	BT30AD-EZ08SU-120	22	120	-	12	20	-	8	27	37	M6*P1.0	1.00
○	BT30AD-EZ10SU-080	22	80	-	14	16	-	10	32	42	M8*P1.0	0.80
○	BT30AD-EZ10SU-120	22	120	-	14	20	-	10	32	42	M8*P1.0	1.10
○	BT30AD-EZ12SU-080	22	80	-	16	16	-	12	37	48	M10*P1.0	0.80
○	BT30AD-EZ12SU-120	22	120	-	16	20	-	12	37	48	M10*P1.0	1.10

產品FIG.22出貨附件為長度調整螺絲BK-EZ-Mxx*1pc // PRODUCTS IN FIG.22 EQUIP WITH BACK UP SCREW BK-EZ-Mxx*1PC
STOCK ○=標準在庫品 // STOCK ◎=regular stock | STOCK ○=少量在庫品 // STOCK ○=few stock | STOCK無標示=接單生產品 // STOCK BLANK=on request

■ SlimUltra shrink fit chucks

● 極細型熱膨脹燒結刀桿

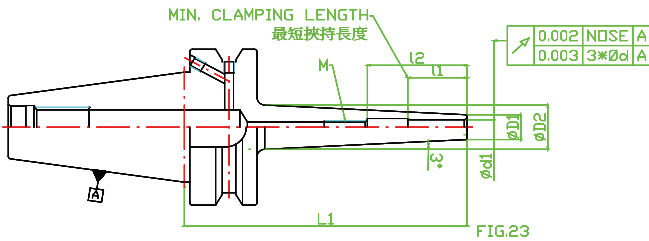

動平衡G2.5/25,000RPM可以另外施作 // BALANCE TO G2.5/25,000RPM IS AVAILABLE ON REQUEST

STOCK	CODE	FIG.	L1	L2	ØD1	ØD2	ØD3	Ød	I1-min. 最短夾持長度 Min. Clamping Length	I2-max. 最長夾持長度 Max. Clamping Length	止動螺絲 (M) Screw Page 153	重量 (KG) Weight
○	BT40AD/B-EZ06SU-105	23	105	-	10	18	-	6	23	37	M5*P0.8	1.30
○	BT40AD/B-EZ08SU-105	23	105	-	12	20	-	8	37	37	M6*P1.0	1.30
○	BT40AD/B-EZ10SU-105	23	105	-	14	22	-	10	32	42	M8*P1.0	1.40
○	BT40AD/B-EZ12SU-105	23	105	-	16	24	-	12	37	48	M10*P1.0	1.40

產品 FIG.23 出貨附件為長度調整螺絲BK-EZ-Mxx*1pc // PRODUCTS IN FIG.23 EQUIP WITH BACK UP SCREW BK-EZ-Mxx*1PC
 STOCK ◎=標準在庫品 // STOCK ◎=regular stock | STOCK ○=少量在庫品 // STOCK ○=few stock | STOCK 無標示=接單生產品 // STOCK
 BLANK=on request

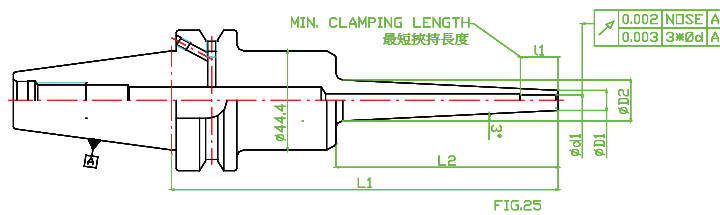
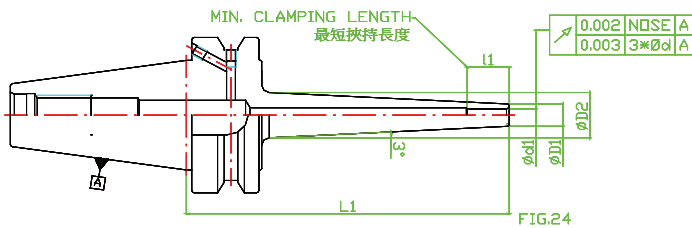

動平衡G2.5/25,000RPM可以另外施作 // BALANCE TO G2.5/25,000RPM IS AVAILABLE ON REQUEST

STOCK	CODE	FIG.	L1	L2	ØD1	ØD2	ØD3	Ød	I1-min. 最短夾持長度 Min. Clamping Length	I2-max. 最長夾持長度 Max. Clamping Length	止動螺絲 (M) Screw Page 153	重量 (KG) Weight
○	BT40AD/B-EZX03SU-090	24	90	62	7	14	-	3	15	-	-	1.10
◎	BT40AD/B-EZX03SU-120	24	120	92	7	17	-	3	15	-	-	1.40
○	BT40AD/B-EZX03SU-160	24	160	132	7	21	-	3	15	-	-	1.70
○	BT40AD/B-EZX03SU-200	25	200	132	7	21	-	3	15	-	-	2.10
○	BT40AD/B-EZX04SU-090	24	90	62	8	15	-	4	17	-	-	1.10
◎	BT40AD/B-EZX04SU-120	24	120	92	8	18	-	4	17	-	-	1.40
○	BT40AD/B-EZX04SU-160	24	160	132	8	22	-	4	17	-	-	1.70
○	BT40AD/B-EZX04SU-200	25	200	132	8	22	-	4	17	-	-	2.10
○	BT40AD/B-EZX05SU-090	24	90	62	9	16	-	5	17	-	-	1.10
◎	BT40AD/B-EZX05SU-120	24	120	92	9	19	-	5	17	-	-	1.40
○	BT40AD/B-EZX05SU-160	24	160	132	9	23	-	5	17	-	-	1.70
○	BT40AD/B-EZX05SU-200	25	200	132	9	23	-	5	17	-	-	2.10

STOCK ◎=標準在庫品 // STOCK ◎=regular stock | STOCK ○=少量在庫品 // STOCK ○=few stock | STOCK 無標示=接單生產品 // STOCK
 BLANK=on request

BT-EZSU

■ SlimUltra shrink fit chucks

● 極細型熱膨脹燒結刀桿

70

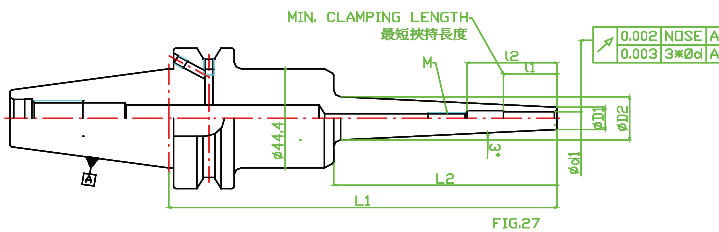
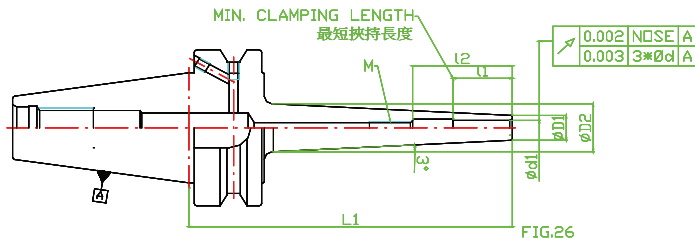

動平衡G2.5/25,000RPM可以另外施作 // BALANCE TO G2.5/25,000RPM IS AVAILABLE ON REQUEST

STOCK	CODE	FIG.	L1	L2	ØD1	ØD2	ØD3	Ød	l1-min. 最短夾持長度 Min. Clamping Length	l2-max. 最長夾持長度 Max. Clamping Length	止動螺絲 (M) Screw Page 153	重量 (KG) Weight
○	BT40AD/B-EZX06SU-090	26	90	62	10	17	-	6	23	37	M5*P0.8	1.20
◎	BT40AD/B-EZX06SU-120	26	120	92	10	20	-	6	23	37	M5*P0.8	1.50
○	BT40AD/B-EZX06SU-160	26	160	132	10	24	-	6	23	37	M5*P0.8	1.80
○	BT40AD/B-EZX06SU-200	27	200	132	10	24	-	6	23	37	M5*P0.8	2.20
○	BT40AD/B-EZX08SU-090	26	90	62	12	19	-	8	27	37	M6*P1.0	1.20
◎	BT40AD/B-EZX08SU-120	26	120	92	12	22	-	8	27	37	M6*P1.0	1.50
○	BT40AD/B-EZX08SU-160	26	160	132	12	26	-	8	27	37	M6*P1.0	1.80
○	BT40AD/B-EZX08SU-200	27	200	132	12	26	-	8	27	37	M6*P1.0	2.20
○	BT40AD/B-EZX10SU-090	26	90	62	14	21	-	10	32	42	M8*P1.0	1.30
◎	BT40AD/B-EZX10SU-120	26	120	92	14	24	-	10	32	42	M8*P1.0	1.60
○	BT40AD/B-EZX10SU-160	26	160	132	14	28	-	10	32	42	M8*P1.0	1.90
○	BT40AD/B-EZX10SU-200	27	200	132	14	28	-	10	32	42	M8*P1.0	2.30
○	BT40AD/B-EZX12SU-090	26	90	62	16	23	-	12	37	48	M10*P1.0	1.30
◎	BT40AD/B-EZX12SU-120	26	120	92	16	26	-	12	37	48	M10*P1.0	1.60
○	BT40AD/B-EZX12SU-160	26	160	132	16	30	-	12	37	48	M10*P1.0	1.90
○	BT40AD/B-EZX12SU-200	27	200	132	16	30	-	12	37	48	M10*P1.0	2.30

產品 FIG.26 & 27 出貨附件為長度調整螺絲BK-EZ-Mxx*1pc // PRODUCTS IN FIG.26 & 27 EQUIP WITH BACK UP SCREW BK-EZ-Mxx*1PC
 STOCK ◎=標準在庫品 // STOCK ◎=regular stock | STOCK ○=少量在庫品 // STOCK ○=few stock | STOCK 無標示=接單生產品 // STOCK
 BLANK=on request

■ SlimUltra shrink fit chucks

● 極細型熱膨脹燒結刀桿

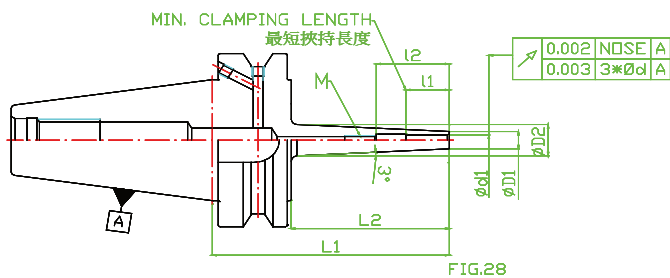

71

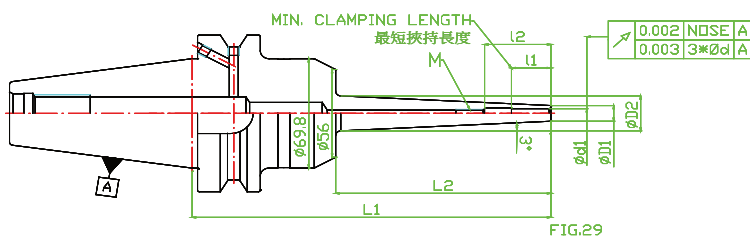

動平衡G2.5/25,000RPM可以另外施作 // BALANCE TO G2.5/25,000RPM IS AVAILABLE ON REQUEST

STOCK	CODE	FIG.	L1	L2	ØD1	ØD2	ØD3	Ød	l1-min. 最短夾持長度 Min. Clamping Length	l2-max. 最長夾持長度 Max. Clamping Length	止動螺絲 (M) Screw Page 153	重量 (KG) Weight
○	BT50AD/B-EZX06SU-100	28	100	60	10	16	-	6	23	37	M5*P0.8	3.80
○	BT50AD/B-EZX06SU-120	28	120	80	10	18	-	6	23	37	M5*P0.8	3.90
○	BT50AD/B-EZX06SU-160	28	160	120	10	22	-	6	23	37	M5*P0.8	4.20
○	BT50AD/B-EZX06SU-200	29	200	120	10	22	-	6	23	37	M5*P0.8	5.80
○	BT50AD/B-EZX08SU-100	28	100	60	12	18	-	8	27	37	M6*P1.0	3.80
○	BT50AD/B-EZX08SU-120	28	120	80	12	20	-	8	27	37	M6*P1.0	3.90
○	BT50AD/B-EZX08SU-160	28	160	120	12	24	-	8	27	37	M6*P1.0	4.20
○	BT50AD/B-EZX08SU-200	29	200	120	12	24	-	8	27	37	M6*P1.0	5.80
○	BT50AD/B-EZX10SU-100	28	100	60	14	20	-	10	32	42	M8*P1.0	3.90
○	BT50AD/B-EZX10SU-120	28	120	80	14	22	-	10	32	42	M8*P1.0	4.00
○	BT50AD/B-EZX10SU-160	28	160	120	14	26	-	10	32	42	M8*P1.0	4.30
○	BT50AD/B-EZX10SU-200	29	200	120	14	26	-	10	32	42	M8*P1.0	5.90
○	BT50AD/B-EZX12SU-100	28	100	60	16	22	-	12	37	48	M10*P1.0	3.90
○	BT50AD/B-EZX12SU-120	28	120	80	16	24	-	12	37	48	M10*P1.0	4.00
○	BT50AD/B-EZX12SU-160	28	160	120	16	28	-	12	37	48	M10*P1.0	4.30
○	BT50AD/B-EZX12SU-200	29	200	120	16	28	-	12	37	48	M10*P1.0	5.90

產品FIG.28 & 29出貨附件為長度調整螺絲BK-EZ-Mxx*1pc // PRODUCTS IN FIG.28 & 29 EQUIP WITH BACK UP SCREW BK-EZ-Mxx*1PC
 STOCK ◎=標準在庫品 // STOCK ○=regular stock | STOCK ○=少量在庫品 // STOCK ○=few stock | STOCK無標示=接單生產品 // STOCK BLANK=on request

BT-EZS

■ Slim shrink fit chucks

● 細型熱膨脹燒結刀桿

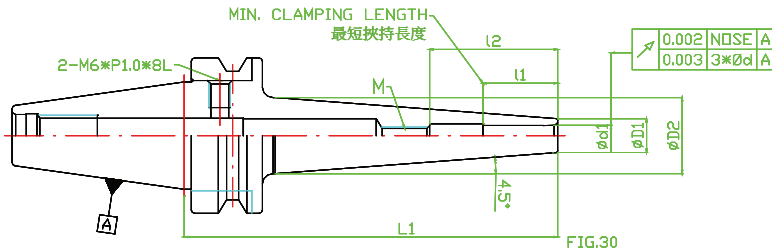

動平衡G2.5/25,000RPM可以另外施作 // BALANCE TO G2.5/25,000RPM IS AVAILABLE ON REQUEST

STOCK	CODE	FIG.	L1	L2	ØD1	ØD2	ØD3	Ød	l1-min. 最短夾持長度 Min. Clamping Length	l2-max. 最長夾持長度 Max. Clamping Length	止動螺絲 (M) Screw Page 153	重量 (KG) Weight
○	BT30AD-EZ06S-105	30	105	-	10	23	-	6	23	37	M5*P0.8	0.80
○	BT30AD-EZ08S-105	30	105	-	12	25	-	8	27	37	M6*P1.0	0.80
○	BT30AD-EZ10S-105	30	105	-	14	27	-	10	32	42	M8*P1.25	0.90
○	BT30AD-EZ12S-105	30	105	-	16	29	-	12	37	48	M10*P1.5	0.90

產品FIG.30出貨附件為長度調整螺絲BK-EZ-Mxx*1pc // PRODUCTS IN FIG.30 EQUIP WITH BACK UP SCREW BK-EZ-Mxx*1PC
 STOCK ◎=標準在庫品 // STOCK ◎=regular stock | STOCK ○=少量在庫品 // STOCK ○=few stock | STOCK無標示=接單生產品 // STOCK
 BLANK=on request

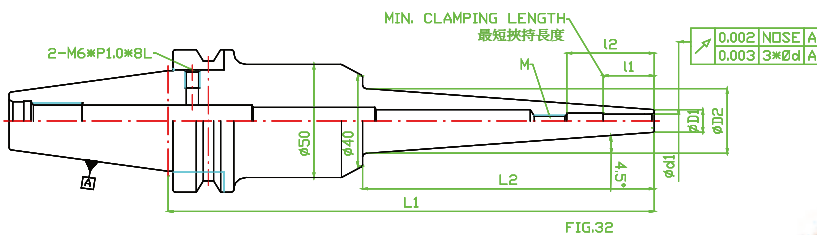
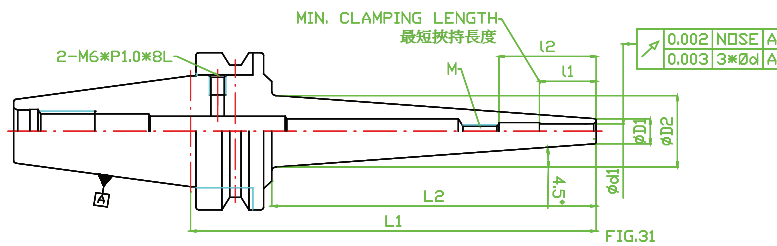

動平衡G2.5/25,000RPM可以另外施作 // BALANCE TO G2.5/25,000RPM IS AVAILABLE ON REQUEST

STOCK	CODE	FIG.	L1	L2	ØD1	ØD2	ØD3	Ød	l1-min. 最短夾持長度 Min. Clamping Length	l2-max. 最長夾持長度 Max. Clamping Length	止動螺絲 (M) Screw Page 153	重量 (KG) Weight
○	BT40AD-EZX06S-150	31	150	120	10	29	-	6	23	37	M5*P0.8	1.70
○	BT40AD-EZX06S-200	32	200	120	10	29	-	6	23	37	M5*P0.8	2.20
○	BT40AD-EZX08S-150	31	150	120	12	31	-	8	27	37	M6*P1.0	1.70
○	BT40AD-EZX08S-200	32	200	120	12	31	-	8	27	37	M6*P1.0	2.20
○	BT40AD-EZX10S-150	31	150	120	14	33	-	10	32	42	M8*P1.25	1.80
○	BT40AD-EZX10S-200	32	200	120	14	33	-	10	32	42	M8*P1.25	2.30
○	BT40AD-EZX12S-150	31	150	120	16	35	-	12	37	48	M10*P1.5	1.80
○	BT40AD-EZX12S-200	32	200	120	16	35	-	12	37	48	M10*P1.5	2.30

產品FIG.31 & 32出貨附件為長度調整螺絲BK-EZ-Mxx*1pc // PRODUCTS IN FIG.31 & 32 EQUIP WITH BACK UP SCREW BK-EZ-Mxx*1PC
 STOCK ◎=標準在庫品 // STOCK ◎=regular stock | STOCK ○=少量在庫品 // STOCK ○=few stock | STOCK無標示=接單生產品 // STOCK
 BLANK=on request

■ Slim shrink fit chucks

● 細型熱膨脹燒結刀桿

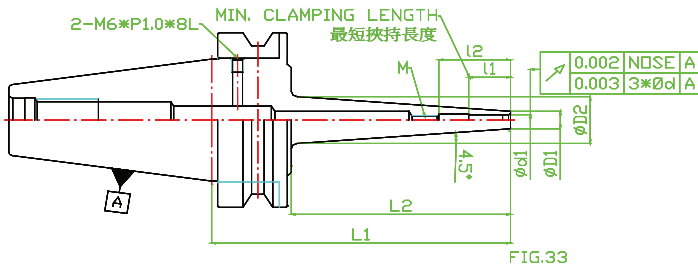

FIG.33

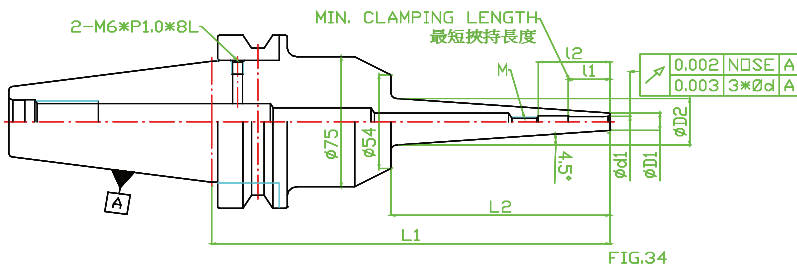

FIG.34



動平衡G2.5/25,000RPM可以另外施作 // BALANCE TO G2.5/25,000RPM IS AVAILABLE ON REQUEST

STOCK	CODE	FIG.	L1	L2	ØD1	ØD2	ØD3	Ød	l1-min. 最短夾持長度 Min. Clamping Length	l2-max. 最長夾持長度 Max. Clamping Length	止動螺絲 (M) Screw Page 153	重量 (KG) Weight
○	BT50AD-EZX06S-150	33	150	110	10	27	-	6	23	37	M5*P0.8	4.10
○	BT50AD-EZX06S-200	34	200	110	10	27	-	6	23	37	M5*P0.8	5.60
○	BT50AD-EZX08S-150	33	150	110	12	29	-	8	27	37	M6*P1.0	4.10
○	BT50AD-EZX08S-200	34	200	110	12	29	-	8	27	37	M6*P1.0	5.60
○	BT50AD-EZX10S-150	33	150	110	14	31	-	10	32	42	M8*P1.25	4.20
○	BT50AD-EZX10S-200	34	200	110	14	31	-	10	32	42	M8*P1.25	5.70
○	BT50AD-EZX12S-150	33	150	110	16	33	-	12	37	48	M10*P1.5	4.20
○	BT50AD-EZX12S-200	34	200	110	16	33	-	12	37	48	M10*P1.5	5.70

產品FIG.31 & 32出貨附件為長度調整螺絲BK-EZ-Mxx*1pc // PRODUCTS IN FIG.31 & 32 EQUIP WITH BACK UP SCREW BK-EZ-Mxx*1PC
 STOCK ◎=標準在庫品 // STOCK ○=regular stock | STOCK ◯=少量在庫品 // STOCK ○=few stock | STOCK 無標示=接單生產品 // STOCK BLANK=on request

BT-EZS

■ Slim shrink fit chucks

● 細型熱膨脹燒結刀桿

74

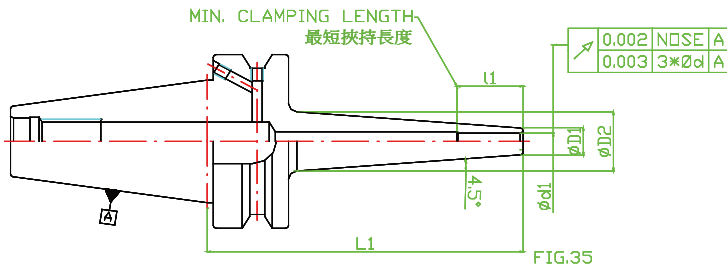

動平衡G2.5/25,000RPM可以另外施作 // BALANCE TO G2.5/25,000RPM IS AVAILABLE ON REQUEST

STOCK	CODE	FIG.	L1	L2	ØD1	ØD2	ØD3	Ød	l1-min. 最短夾持長度 Min. Clamping Length	l2-max. 最長夾持長度 Max. Clamping Length	止動螺絲 (M) Screw Page 153	重量 (KG) Weight
	BT40AD/B-EZ03S-120	35	120	-	9	24	-	3	15	-	-	1.40
	BT40AD/B-EZ04S-120	35	120	-	9	24	-	4	17	-	-	1.40
	BT40AD/B-EZ05S-120	35	120	-	9	24	-	5	17	-	-	1.40

STOCK ◎=標準在庫品 // STOCK ◎=regular stock | STOCK ○=少量在庫品 // STOCK ○=few stock | STOCK 無標示=接單生產品 // STOCK BLANK=on request

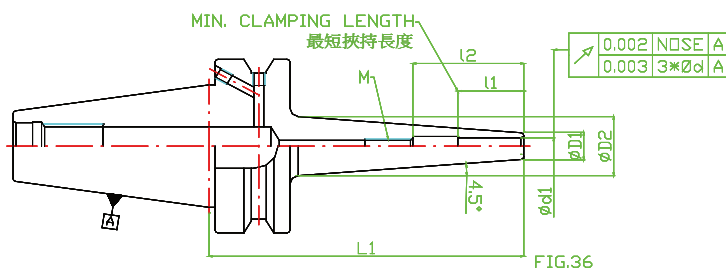

動平衡G2.5/25,000RPM可以另外施作 // BALANCE TO G2.5/25,000RPM IS AVAILABLE ON REQUEST

STOCK	CODE	FIG.	L1	L2	ØD1	ØD2	ØD3	Ød	l1-min. 最短夾持長度 Min. Clamping Length	l2-max. 最長夾持長度 Max. Clamping Length	止動螺絲 (M) Screw Page 153	重量 (KG) Weight
	BT40AD/B-EZ06S-120	36	120	-	15	29	-	6	23	37	M5*P0.8	1.50
	BT40AD/B-EZ08S-120	36	120	-	15	29	-	8	27	37	M6*P1.0	1.50
	BT40AD/B-EZ10S-120	36	120	-	18	31	-	10	32	42	M8*P1.0	1.60
	BT40AD/B-EZ12S-120	36	120	-	18	31	-	12	37	48	M10*P1.0	1.60

產品 FIG.36 出貨附件為長度調整螺絲BK-EZ-Mxx*1pc // PRODUCTS IN FIG.36 EQUIP WITH BACK UP SCREW BK-EZ-Mxx*1PC
STOCK ◎=標準在庫品 // STOCK ◎=regular stock | STOCK ○=少量在庫品 // STOCK ○=few stock | STOCK 無標示=接單生產品 // STOCK BLANK=on request

■ SlimSuper shrink fit chucks

● 超細型熱膨脹燒結刀桿

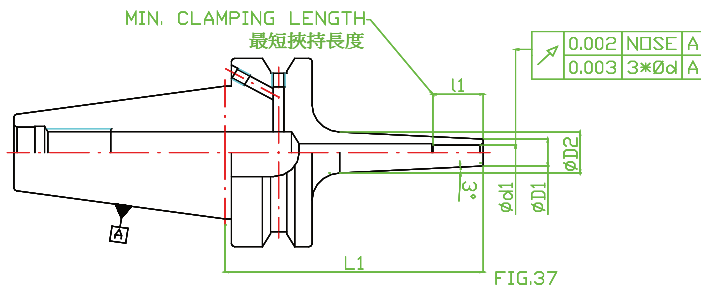

動平衡G2.5/25,000RPM可以另外施作 // BALANCE TO G2.5/25,000RPM IS AVAILABLE ON REQUEST

STOCK	CODE	FIG.	L1	L2	ØD1	ØD2	ØD3	Ød	l1-min. 最短夾持長度 Min. Clamping Length	l2-max. 最長夾持長度 Max. Clamping Length	止動螺絲 (M) Screw Page 153	重量 (KG) Weight
	BT40AD/B-EZ06SS-090	37	90	-	12	19	-	6	23	-	-	1.20
	BT40AD/B-EZ08SS-090	37	90	-	14	21	-	8	27	-	-	1.20
	BT40AD/B-EZ10SS-090	37	90	-	16	23	-	10	32	-	-	1.30
	BT40AD/B-EZ12SS-090	37	90	-	18	25	-	12	37	-	-	1.30
	BT40AD/B-EZ06SS-120	37	120	-	12	22	-	6	23	-	-	1.50
	BT40AD/B-EZ08SS-120	37	120	-	14	24	-	8	27	-	-	1.50
	BT40AD/B-EZ10SS-120	37	120	-	16	26	-	10	32	-	-	1.60
	BT40AD/B-EZ12SS-120	37	120	-	18	28	-	12	37	-	-	1.60

產品FIG.36出貨附件為長度調整螺絲BK-EZ-Mxx*1pc // PRODUCTS IN FIG.36 EQUIP WITH BACK UP SCREW BK-EZ-Mxx*1PC
 STOCK ◎=標準在庫品 // STOCK ◎=regular stock | STOCK ○=少量在庫品 // STOCK ○=few stock | STOCK 無標示=接單生產品 // STOCK
 BLANK=on request

BT-BTG-EZ

■ Shrink fit chucks without drive key slots

● 無傳動鍵槽熱膨脹燒結刀桿

76

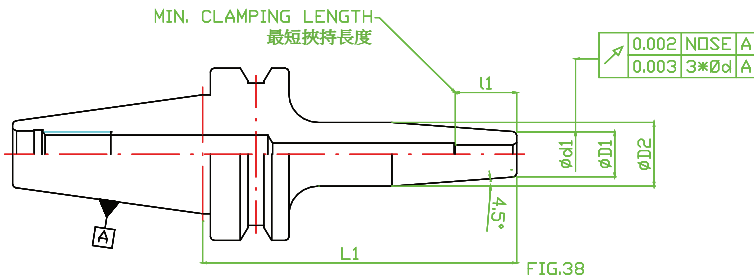

動平衡G2.5/25,000RPM可以另外施作 // BALANCE TO G2.5/25,000RPM IS AVAILABLE ON REQUEST

STOCK	CODE	FIG.	L1	L2	ØD1	ØD2	ØD3	Ød	I1-min. 最短夾持長度 Min. Clamping Length	I2-max. 最長夾持長度 Max. Clamping Length	止動螺絲 (M) Screw Page 153	重量 (KG) Weight
◎	BT30GAD-EZ03-080	38	80	-	12	17	-	3	11	-	-	0.60
◎	BT30GAD-EZ04-080	38	80	-	12	17	-	4	14	-	-	0.60
◎	BT30GAD-EZ05-080	38	80	-	12	17	-	5	17	-	-	0.60

STOCK ◎=標準在庫品 // STOCK ◎=regular stock | STOCK ○=少量在庫品 // STOCK ○=few stock | STOCK 無標示=接單生產品 // STOCK BLANK=on request

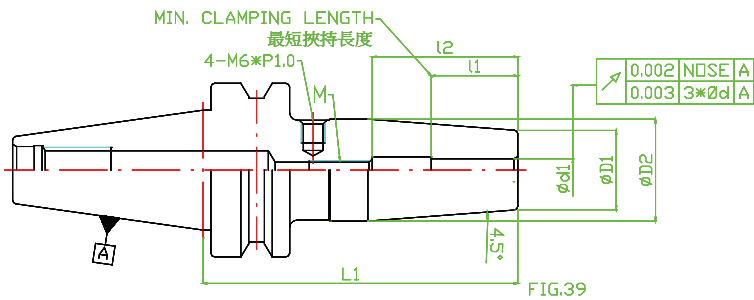

動平衡G2.5/25,000RPM可以另外施作 // BALANCE TO G2.5/25,000RPM IS AVAILABLE ON REQUEST

STOCK	CODE	FIG.	L1	L2	ØD1	ØD2	ØD3	Ød	I1-min. 最短夾持長度 Min. Clamping Length	I2-max. 最長夾持長度 Max. Clamping Length	止動螺絲 (M) Screw Page 153	重量 (KG) Weight
◎	BT30GAD-EZ06-080	39	80	-	21	27	-	6	23	37	M5*P0.8	0.70
◎	BT30GAD-EZ08-080	39	80	-	21	27	-	8	27	37	M6*P1.0	0.70
◎	BT30GAD-EZ10-080	39	80	-	24	32	-	10	32	42	M8*P1.0	0.80
◎	BT30GAD-EZ12-080	39	80	-	24	32	-	12	37	48	M10*P1.0	0.80
◎	BT30GAD-EZ14-080	39	80	-	27	34	-	14	37	48	M10*P1.0	0.80
◎	BT30GAD-EZ16-080	39	80	-	27	34	-	16	40	51	M12*P1.0	0.80
	BT30GAD-EZ18-090	39	90	-	33	42	-	18	40	51	M12*P1.0	1.00
	BT30GAD-EZ20-090	39	90	-	33	42	-	20	42	53	M16*P1.0	1.00

產品FIG.39出貨附件為長度調整螺絲BK-EZ-Mxx*1pc // PRODUCTS IN FIG.39 EQUIP WITH BACK UP SCREW BK-EZ-Mxx*1PC
STOCK ◎=標準在庫品 // STOCK ◎=regular stock | STOCK ○=少量在庫品 // STOCK ○=few stock | STOCK 無標示=接單生產品 // STOCK BLANK=on request

SGER power ER collet chucks

SGER 強力型 ER 筒夾刀桿

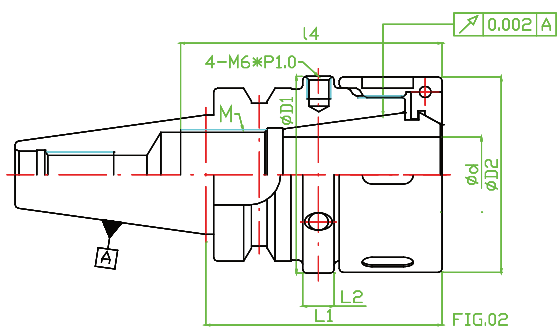
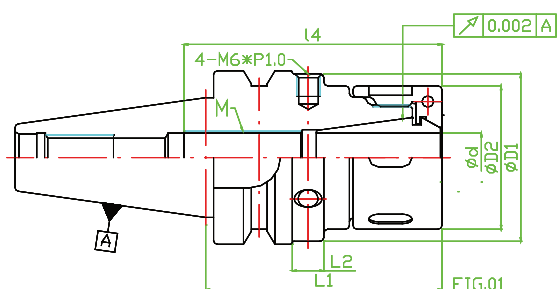

動平衡G2.5/25,000RPM可以另外施作 // BALANCE TO G2.5/25,000RPM IS AVAILABLE ON REQUEST

STOCK	CODE	FIG.	L1	L2	L3	L4	D1	D2	d	止動螺絲 (M) Screw Page 154	筒夾 COLLET Page 143	螺帽 NUT Page 151	扳手 WRENCH Page 154	重量 (KG) Weight
◎	BT30AD-SGER16-060	1	60	9	-	46	44.4	34	0.5~10.0	M11*P1.0	ER16	N16SGXnano	W-FK04	0.60
◎	BT30AD-SGER16-100	1	100	9	-	46	44.4	34	0.5~10.0	M11*P1.0	ER16	N16SGXnano	W-FK04	0.80
◎	BT30AD-SGER20-060	1	60	9	-	51	44.4	38	0.5~13.0	M14*P1.0	ER20	N20SGXnano	W-FK05	0.70
◎	BT30AD-SGER20-100	1	100	9	-	51	44.4	38	0.5~13.0	M14*P1.0	ER20	N20SGXnano	W-FK05	0.90
◎	BT30AD-SGER25-060	1	60	9	-	53	44.4	44	0.5~16.0	M18*P1.5	ER25	N25SGXnano	W-FK06	0.90
◎	BT30AD-SGER25-100	1	100	9	-	53	44.4	44	0.5~16.0	M18*P1.5	ER25	N25SGXnano	W-FK06	1.30
◎	BT30AD-SGER32-060	2	60	8	-	47	52.4	52	2.0~20.0	M24*P1.5	ER32	N32SGXnano	W-FK08	1.00
◎	BT30AD-SGER32-100	2	100	8	-	57	52.4	52	2.0~20.0	M24*P1.5	ER32	N32SGXnano	W-FK08	1.40

產品FIG.1, 2 出貨附件為高速平衡奈米鋼珠螺帽

NxxSGX nano*1pc // PRODUCTS IN FIG.1, 2 EQUIP WITH BALANCED NANO BALL BEARING NUT NxxSGX nano*1pc

STOCK ◎=標準在庫品 // STOCK ○=regular stock | STOCK ◯=少量在庫品 // STOCK ◯=few stock | STOCK無標示=接單生產品 // STOCK

BLANK=on request

ER筒夾和扳手是另購品 // ER COLLET AND WRENCH TO BE ORDERED SEPARATELY

BT-SGER

SGER power ER collet chucks

SGER 強力型 ER 筒夾刀桿

78

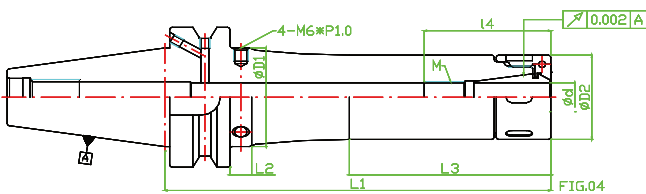
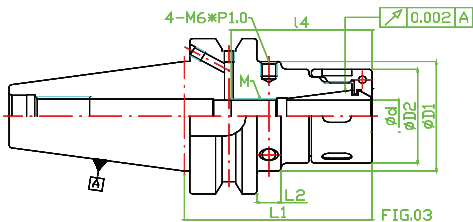

動平衡G2.5/25,000RPM可以另外施作 // BALANCE TO G2.5/25,000RPM IS AVAILABLE ON REQUEST

STOCK	CODE	FIG.	L1	L2	L3	L4	D1	D2	d	止動螺絲 (M) Screw Page 154	筒夾 COLLET Page 143	螺帽 NUT Page 151	扳手 WRENCH Page 154	重量 (KG) Weight
◎	BT40AD/B-SGER16-070	3	70	9	-	39	44.4	34	0.5~10.0	M11*P1.0	ER16	N16SGX nano	W-FK04	1.20
◎	BT40AD/B-SGER16-100	3	100	9	-	46	44.4	34	0.5~10.0	M11*P1.0	ER16	N16SGX nano	W-FK04	1.40
◎	BT40AD/B-SGER16-120	3	120	9	-	46	44.4	34	0.5~10.0	M11*P1.0	ER16	N16SGX nano	W-FK04	1.50
○	BT40AD/B-SGER16-160	4	160	9	86	46	44.4	34	0.5~10.0	M11*P1.0	ER16	N16SGX nano	W-FK04	1.90
	BT40AD/B-SGER16-200	4	200	9	126	46	44.4	34	0.5~10.0	M11*P1.0	ER16	N16SGX nano	W-FK04	2.30
◎	BT40AD/B-SGER20-070	3	70	9	-	38	44.4	38	0.5~13.0	M14*P1.0	ER20	N20SGX nano	W-FK05	1.30
◎	BT40AD/B-SGER20-100	3	100	9	-	51	44.4	38	0.5~13.0	M14*P1.0	ER20	N20SGX nano	W-FK05	1.50
◎	BT40AD/B-SGER20-120	3	120	9	-	51	44.4	38	0.5~13.0	M14*P1.0	ER20	N20SGX nano	W-FK05	1.60
○	BT40AD/B-SGER20-160	4	160	9	86	51	44.4	38	0.5~13.0	M14*P1.0	ER20	N20SGX nano	W-FK05	2.00
	BT40AD/B-SGER20-200	4	200	9	126	51	44.4	38	0.5~13.0	M14*P1.0	ER20	N20SGX nano	W-FK05	2.40
◎	BT40AD/B-SGER25-070	3	70	9	-	53	44.4	44	0.5~16.0	M18*P1.5	ER25	N25SGX nano	W-FK06	1.50
◎	BT40AD/B-SGER25-100	3	100	9	-	53	44.4	44	0.5~16.0	M18*P1.5	ER25	N25SGX nano	W-FK06	1.80
◎	BT40AD/B-SGER25-120	3	120	9	-	53	44.4	44	0.5~16.0	M18*P1.5	ER25	N25SGX nano	W-FK06	2.00
○	BT40AD/B-SGER25-160	3	160	9	-	53	44.4	44	0.5~16.0	M18*P1.5	ER25	N25SGX nano	W-FK06	2.40
	BT40AD/B-SGER25-200	3	200	9	-	53	44.4	44	0.5~16.0	M18*P1.5	ER25	N25SGX nano	W-FK06	2.80
◎	BT40AD/B-SGER32-070	3	70	9	-	57	52.4	52	2.0~20.0	M24*P1.5	ER32	N32SGX nano	W-FK08	1.60
◎	BT40AD/B-SGER32-100	3	100	9	-	57	52.4	52	2.0~20.0	M24*P1.5	ER32	N32SGX nano	W-FK08	1.90
◎	BT40AD/B-SGER32-120	3	120	9	-	57	52.4	52	2.0~20.0	M24*P1.5	ER32	N32SGX nano	W-FK08	2.10
○	BT40AD/B-SGER32-160	3	160	9	-	57	52.4	52	2.0~20.0	M24*P1.5	ER32	N32SGX nano	W-FK08	2.40
	BT40AD/B-SGER32-200	3	200	9	-	57	52.4	52	2.0~20.0	M24*P1.5	ER32	N32SGX nano	W-FK08	2.90
◎	BT40AD/B-SGER40-070	3	70	9	-	62	62.4	62	3.0~26.0	M28*P1.5	ER40	N40SGX nano	W-FK09	2.00
◎	BT40AD/B-SGER40-100	3	100	9	-	67	62.4	62	3.0~26.0	M28*P1.5	ER40	N40SGX nano	W-FK09	2.30
◎	BT40AD/B-SGER40-120	3	120	9	-	67	62.4	62	3.0~26.0	M28*P1.5	ER40	N40SGX nano	W-FK09	2.60
○	BT40AD/B-SGER40-160	3	160	9	-	67	62.4	62	3.0~26.0	M28*P1.5	ER40	N40SGX nano	W-FK09	3.20
	BT40AD/B-SGER40-200	3	200	9	-	67	62.4	62	3.0~26.0	M28*P1.5	ER40	N40SGX nano	W-FK09	3.80

產品FIG.3.4出貨附件為高速平衡奈米鋼珠螺帽

NxxSGX nano*1pc // PRODUCTS IN FIG.3.4 EQUIP WITH BALANCED NANO BALL BEARING NUT NxxSGX nano*1pc

STOCK ◎=標準在庫品 // STOCK ○=regular stock | STOCK ○=少量在庫品 // STOCK ○=few stock | STOCK無標示=接單生產品 // STOCK

BLANK=on request

ER筒夾和扳手是另購品 // ER COLLET AND WRENCH TO BE ORDERED SEPARATELY

SGER power ER collet chucks

SGER 強力型 ER 筒夾刀桿

動平衡G2.5/25,000RPM可以另外施作 // BALANCE TO G2.5/25,000RPM IS AVAILABLE ON REQUEST

STOCK	CODE	FIG.	L1	L2	L3	L4	D1	D2	d	止動螺絲 (M) Screw Page 154	筒夾 COLLET Page 143	螺帽 NUT Page 151	扳手 WRENCH Page 154	重量 (KG) Weight
◎	BT50AD/B-SGER16-080	3	80	9	-	46	69.8	34	0.5~10.0	M11*P1.0	ER16	N16SGX nano	W-FK04	4.10
◎	BT50AD/B-SGER16-100	3	100	9	-	46	69.8	34	0.5~10.0	M11*P1.0	ER16	N16SGX nano	W-FK04	4.20
◎	BT50AD/B-SGER16-120	3	120	9	-	46	69.8	34	0.5~10.0	M11*P1.0	ER16	N16SGX nano	W-FK04	4.30
○	BT50AD/B-SGER16-160	4	160	9	70	46	69.8	34	0.5~10.0	M11*P1.0	ER16	N16SGX nano	W-FK04	4.70
	BT50AD/B-SGER16-200	4	200	9	110	46	69.8	34	0.5~10.0	M11*P1.0	ER16	N16SGX nano	W-FK04	5.10
◎	BT50AD/B-SGER20-080	3	80	9	-	51	69.8	38	0.5~13.0	M14*P1.0	ER20	N20SGX nano	W-FK05	4.20
◎	BT50AD/B-SGER20-100	3	100	9	-	51	69.8	38	0.5~13.0	M14*P1.0	ER20	N20SGX nano	W-FK05	4.30
◎	BT50AD/B-SGER20-120	3	120	9	-	51	69.8	38	0.5~13.0	M14*P1.0	ER20	N20SGX nano	W-FK05	4.40
○	BT50AD/B-SGER20-160	4	160	9	70	51	69.8	38	0.5~13.0	M14*P1.0	ER20	N20SGX nano	W-FK05	4.80
	BT50AD/B-SGER20-200	4	200	9	110	51	69.8	38	0.5~13.0	M14*P1.0	ER20	N20SGX nano	W-FK05	5.20
◎	BT50AD/B-SGER25-080	3	80	9	-	53	69.8	44	0.5~16.0	M18*P1.5	ER25	N25SGX nano	W-FK06	4.40
◎	BT50AD/B-SGER25-100	3	100	9	-	53	69.8	44	0.5~16.0	M18*P1.5	ER25	N25SGX nano	W-FK06	4.60
◎	BT50AD/B-SGER25-120	3	120	9	-	53	69.8	44	0.5~16.0	M18*P1.5	ER25	N25SGX nano	W-FK06	4.80
○	BT50AD/B-SGER25-160	4	160	9	70	53	69.8	44	0.5~16.0	M18*P1.5	ER25	N25SGX nano	W-FK06	5.20
	BT50AD/B-SGER25-200	4	200	9	110	53	69.8	44	0.5~16.0	M18*P1.5	ER25	N25SGX nano	W-FK06	5.60
◎	BT50AD/B-SGER32-080	3	80	9	-	57	69.8	52	2.0~20.0	M24*P1.5	ER32	N32SGX nano	W-FK08	4.50
◎	BT50AD/B-SGER32-100	3	100	9	-	57	69.8	52	2.0~20.0	M24*P1.5	ER32	N32SGX nano	W-FK08	4.70
◎	BT50AD/B-SGER32-120	3	120	9	-	57	69.8	52	2.0~20.0	M24*P1.5	ER32	N32SGX nano	W-FK08	4.90
○	BT50AD/B-SGER32-160	4	160	9	70	57	69.8	52	2.0~20.0	M24*P1.5	ER32	N32SGX nano	W-FK08	5.30
	BT50AD/B-SGER32-200	4	200	9	110	57	69.8	52	2.0~20.0	M24*P1.5	ER32	N32SGX nano	W-FK08	5.70
◎	BT50AD/B-SGER40-080	3	80	9	-	67	69.8	62	3.0~26.0	M28*P1.5	ER40	N40SGX nano	W-FK09	4.90
◎	BT50AD/B-SGER40-100	3	100	9	-	67	69.8	62	3.0~26.0	M28*P1.5	ER40	N40SGX nano	W-FK09	5.10
◎	BT50AD/B-SGER40-120	3	120	9	-	67	69.8	62	3.0~26.0	M28*P1.5	ER40	N40SGX nano	W-FK09	5.30
○	BT50AD/B-SGER40-160	3	160	9	-	67	69.8	62	3.0~26.0	M28*P1.5	ER40	N40SGX nano	W-FK09	5.70
	BT50AD/B-SGER40-200	3	200	9	-	67	69.8	62	3.0~26.0	M28*P1.5	ER40	N40SGX nano	W-FK09	6.10

產品FIG.3,4出貨附件為高速平衡奈米鋼珠螺帽

NxxSGX nano*1pc // PRODUCTS IN FIG.3,4 EQUIP WITH BALANCED NANO BALL BEARING NUT NxxSGX nano*1pc

STOCK ◎=標準在庫品 // STOCK ◎=regular stock | STOCK ○=少量在庫品 // STOCK ○=few stock | STOCK無標示=接單生產品 // STOCK

BLANK=on request

ER筒夾和扳手是另購品 // ER COLLET AND WRENCH TO BE ORDERED SEPARATELY

BT-SGER

■ SGER power ER collet chucks

● SGER 強力型 ER 筒夾刀桿

80

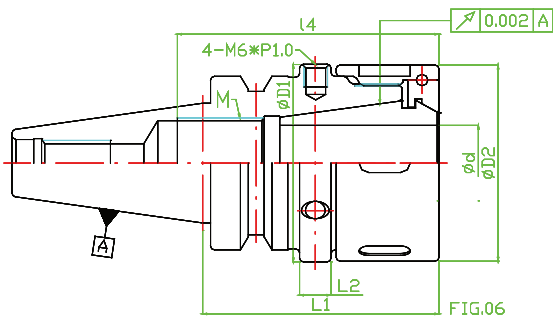
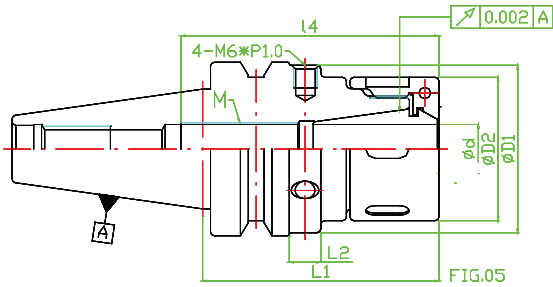

動平衡G2.5/25,000RPM可以另外施作 // BALANCE TO G2.5/25,000RPM IS AVAILABLE ON REQUEST

STOCK	CODE	FIG.	L1	L2	L3	L4	D1	D2	d	止動螺絲 (M) Screw Page 154	筒夾 COLLET Page 143	螺帽 NUT Page 151	板手 WRENCH Page 154	重量 (KG) Weight
○	BT30GAD-SGER16-060	5	60	9	-	46	44.4	34	0.5~10.0	M11*P1.0	ER16	N16SGX nano	W-FK04	0.60
	BT30GAD-SGER16-100	5	100	9	-	46	44.4	34	0.5~10.0	M11*P1.0	ER16	N16SGX nano	W-FK04	0.80
○	BT30GAD-SGER20-060	5	60	9	-	51	44.4	38	0.5~13.0	M14*P1.0	ER20	N20SGX nano	W-FK05	0.70
	BT30GAD-SGER20-100	5	100	9	-	51	44.4	38	0.5~13.0	M14*P1.0	ER20	N20SGX nano	W-FK05	0.90
○	BT30GAD-SGER25-060	5	60	9	-	53	44.4	44	0.5~16.0	M18*P1.5	ER25	N25SGX nano	W-FK06	0.90
	BT30GAD-SGER25-100	5	100	9	-	53	44.4	44	0.5~16.0	M18*P1.5	ER25	N25SGX nano	W-FK06	1.30
○	BT30GAD-SGER32-060	6	60	8	-	47	52.4	52	2.0~20.0	M24*P1.5	ER32	N32SGX nano	W-FK08	1.00
	BT30GAD-SGER32-100	6	100	8	-	57	52.4	52	2.0~20.0	M24*P1.5	ER32	N32SGX nano	W-FK08	1.40

產品FIG.5 & 6出貨附件為高速平衡奈米鋼珠螺帽

NxxSGX nano*1pc // PRODUCTS IN FIG.5 & 6 EQUIP WITH BALANCED NANO BALL BEARING NUT NxxSGX nano*1pc

STOCK ◎=標準在庫品 // STOCK ◎=regular stock | STOCK ○=少量在庫品 // STOCK ○=few stock | STOCK無標示=接單生產品 // STOCK

BLANK=on request

ER筒夾和板手是另購品 // ER COLLET AND WRENCH TO BE ORDERED SEPARATELY

■ SGER power ER collet chucks

● SGER 強力型 ER 筒夾刀桿

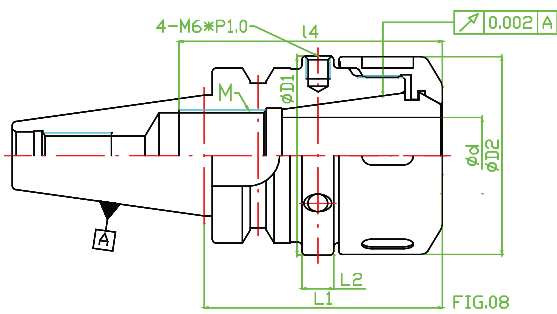
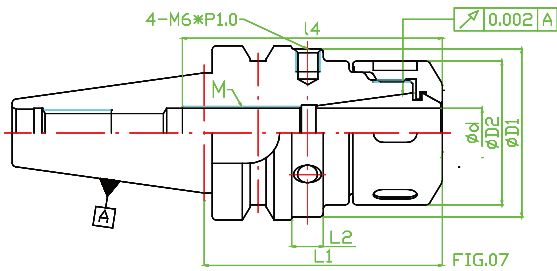

動平衡G2.5/25,000RPM可以另外施作 // BALANCE TO G2.5/25,000RPM IS AVAILABLE ON REQUEST

STOCK	CODE	FIG.	L1	L2	L3	L4	D1	D2	d	止動螺絲 (M) Screw Page 154	筒夾 COLLET Page 143	螺帽 NUT Page 151	扳手 WRENCH Page 154	重量 (KG) Weight
◎	BT30AD-SGER16SX-060	7	60	9	-	46	44.4	34	0.5~10.0	M11*P1.0	ER16	N16SGSX nano	W-FK04	0.60
◎	BT30AD-SGER16SX-100	7	100	9	-	46	44.4	34	0.5~10.0	M11*P1.0	ER16	N16SGSX nano	W-FK04	0.80
◎	BT30AD-SGER20SX-060	7	60	9	-	51	44.4	38	0.5~13.0	M14*P1.0	ER20	N20SGSX nano	W-FK05	0.70
◎	BT30AD-SGER20SX-100	7	100	9	-	51	44.4	38	0.5~13.0	M14*P1.0	ER20	N20SGSX nano	W-FK05	0.90
◎	BT30AD-SGER25SX-060	7	60	9	-	53	44.4	44	0.5~16.0	M18*P1.5	ER25	N25SGSX nano	W-FK06	0.90
◎	BT30AD-SGER25SX-100	7	100	9	-	53	44.4	44	0.5~16.0	M18*P1.5	ER25	N25SGSX nano	W-FK06	1.30
◎	BT30AD-SGER32SX-060	8	60	8	-	47	52.4	52	2.0~20.0	M24*P1.5	ER32	N32SGSX nano	W-FK08	1.00
◎	BT30AD-SGER32SX-100	8	100	8	-	57	52.4	52	2.0~20.0	M24*P1.5	ER32	N32SGSX nano	W-FK08	1.40

產品 FIG.7 & 8 出貨附件為高速平衡奈米螺帽

NxxSGSX nano*1pc // PRODUCTS IN FIG.7 & 8 EQUIP WITH BALANCED NANO NUT NxxSGSX nano*1pc

STOCK ◎=標準在庫品 // STOCK ○=regular stock | STOCK ○=少量在庫品 // STOCK ○=few stock | STOCK無標示=接單生產品 // STOCK BLANK=on request

ER筒夾和扳手是另購品 // ER COLLET AND WRENCH TO BE ORDERED SEPARATELY

BT-SGER

SGER power ER collet chucks

SGER 強力型 ER 筒夾刀桿

82

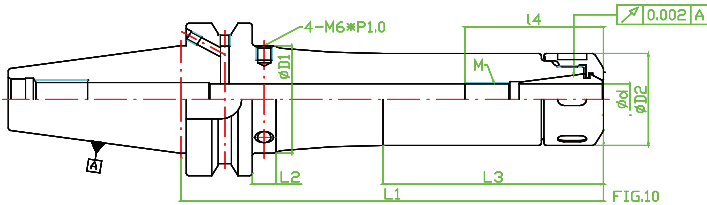
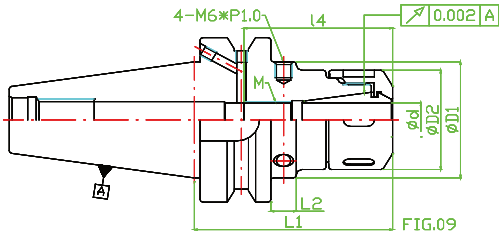

動平衡G2.5/25,000RPM可以另外施作 // BALANCE TO G2.5/25,000RPM IS AVAILABLE ON REQUEST

STOCK	CODE	FIG.	L1	L2	L3	L4	D1	D2	d	止動螺絲 (M) Screw Page 154	筒夾 COLLET Page 143	螺帽 NUT Page 151	扳手 WRENCH Page 154	重量 (KG) Weight
◎	BT40AD/B-SGER16SX-070	9	70	9	-	39	44.4	34	0.5~10.0	M11*P1.0	ER16	N16SGSX nano	W-FK04	1.20
◎	BT40AD/B-SGER16SX-100	9	100	9	-	46	44.4	34	0.5~10.0	M11*P1.0	ER16	N16SGSX nano	W-FK04	1.40
◎	BT40AD/B-SGER16SX-120	9	120	9	-	46	44.4	34	0.5~10.0	M11*P1.0	ER16	N16SGSX nano	W-FK04	1.50
○	BT40AD/B-SGER16SX-160	10	160	9	86	46	44.4	34	0.5~10.0	M11*P1.0	ER16	N16SGSX nano	W-FK04	1.90
	BT40AD/B-SGER16SX-200	10	200	9	126	46	44.4	34	0.5~10.0	M11*P1.0	ER16	N16SGSX nano	W-FK04	2.30
◎	BT40AD/B-SGER20SX-070	9	70	9	-	38	44.4	38	0.5~13.0	M14*P1.0	ER20	N20SGSX nano	W-FK05	1.30
◎	BT40AD/B-SGER20SX-100	9	100	9	-	51	44.4	38	0.5~13.0	M14*P1.0	ER20	N20SGSX nano	W-FK05	1.50
◎	BT40AD/B-SGER20SX-120	9	120	9	-	51	44.4	38	0.5~13.0	M14*P1.0	ER20	N20SGSX nano	W-FK05	1.60
○	BT40AD/B-SGER20SX-160	10	160	9	86	51	44.4	38	0.5~13.0	M14*P1.0	ER20	N20SGSX nano	W-FK05	2.00
	BT40AD/B-SGER20SX-200	10	200	9	126	51	44.4	38	0.5~13.0	M14*P1.0	ER20	N20SGSX nano	W-FK05	2.40
◎	BT40AD/B-SGER25SX-070	9	70	9	-	53	44.4	44	0.5~16.0	M18*P1.5	ER25	N25SGSX nano	W-FK06	1.50
◎	BT40AD/B-SGER25SX-100	9	100	9	-	53	44.4	44	0.5~16.0	M18*P1.5	ER25	N25SGSX nano	W-FK06	1.80
◎	BT40AD/B-SGER25SX-120	9	120	9	-	53	44.4	44	0.5~16.0	M18*P1.5	ER25	N25SGSX nano	W-FK06	2.00
○	BT40AD/B-SGER25SX-160	9	160	9	-	53	44.4	44	0.5~16.0	M18*P1.5	ER25	N25SGSX nano	W-FK06	2.40
	BT40AD/B-SGER25SX-200	9	200	9	-	53	44.4	44	0.5~16.0	M18*P1.5	ER25	N25SGSX nano	W-FK06	2.80
◎	BT40AD/B-SGER32SX-070	9	70	9	-	57	52.4	52	2.0~20.0	M24*P1.5	ER32	N32SGSX nano	W-FK08	1.60
◎	BT40AD/B-SGER32SX-100	9	100	9	-	57	52.4	52	2.0~20.0	M24*P1.5	ER32	N32SGSX nano	W-FK08	1.90
◎	BT40AD/B-SGER32SX-120	9	120	9	-	57	52.4	52	2.0~20.0	M24*P1.5	ER32	N32SGSX nano	W-FK08	2.10
○	BT40AD/B-SGER32SX-160	9	160	9	-	57	52.4	52	2.0~20.0	M24*P1.5	ER32	N32SGSX nano	W-FK08	2.40
	BT40AD/B-SGER32SX-200	9	200	9	-	57	52.4	52	2.0~20.0	M24*P1.5	ER32	N32SGSX nano	W-FK08	2.90
◎	BT40AD/B-SGER40SX-070	9	70	9	-	62	62.4	62	3.0~26.0	M28*P1.5	ER40	N40SGSX nano	W-FK09	2.00
◎	BT40AD/B-SGER40SX-100	9	100	9	-	67	62.4	62	3.0~26.0	M28*P1.5	ER40	N40SGSX nano	W-FK09	2.30
◎	BT40AD/B-SGER40SX-120	9	120	9	-	67	62.4	62	3.0~26.0	M28*P1.5	ER40	N40SGSX nano	W-FK09	2.60
○	BT40AD/B-SGER40SX-160	9	160	9	-	67	62.4	62	3.0~26.0	M28*P1.5	ER40	N40SGSX nano	W-FK09	3.20
	BT40AD/B-SGER40SX-200	9	200	9	-	67	62.4	62	3.0~26.0	M28*P1.5	ER40	N40SGSX nano	W-FK09	3.80

產品 FIG.9 & 10 出貨附件為高速平衡奈米螺帽

NxxSGSX nano*1pc // PRODUCTS IN FIG.9 & 10 EQUIP WITH BALANCED NANO NUT NxxSGSX nano*1pc

STOCK ◎=標準在庫品 // STOCK ○=少量在庫品 // STOCK ○=few stock | STOCK無標示=接單生產品 // STOCK

BLANK=on request

ER筒夾和扳手是另購品 // ER COLLET AND WRENCH TO BE ORDERED SEPARATELY

■ SGER power ER collet chucks

● SGER 強力型 ER 筒夾刀桿

動平衡G2.5/25,000RPM可以另外施作 // BALANCE TO G2.5/25,000RPM IS AVAILABLE ON REQUEST

STOCK	CODE	FIG.	L1	L2	L3	I4	D1	D2	d	止動螺絲 (M) Screw Page 154	筒夾 COLLET Page 143	螺帽 NUT Page 151	扳手 WRENCH Page 154	重量 (KG) Weight
◎	BT50AD/B-SGER16SX-080	9	80	9	-	46	69.8	34	0.5~10.0	M11*P1.0	ER16	N16SGSX nano	W-FK04	4.10
◎	BT50AD/B-SGER16SX-100	9	100	9	-	46	69.8	34	0.5~10.0	M11*P1.0	ER16	N16SGSX nano	W-FK04	4.20
◎	BT50AD/B-SGER16SX-120	9	120	9	-	46	69.8	34	0.5~10.0	M11*P1.0	ER16	N16SGSX nano	W-FK04	4.30
○	BT50AD/B-SGER16SX-160	10	160	9	70	46	69.8	34	0.5~10.0	M11*P1.0	ER16	N16SGSX nano	W-FK04	4.70
	BT50AD/B-SGER16SX-200	10	200	9	110	46	69.8	34	0.5~10.0	M11*P1.0	ER16	N16SGSX nano	W-FK04	5.10
◎	BT50AD/B-SGER20SX-080	9	80	9	-	51	69.8	38	0.5~13.0	M14*P1.0	ER20	N20SGSX nano	W-FK05	4.20
◎	BT50AD/B-SGER20SX-100	9	100	9	-	51	69.8	38	0.5~13.0	M14*P1.0	ER20	N20SGSX nano	W-FK05	4.30
◎	BT50AD/B-SGER20SX-120	9	120	9	-	51	69.8	38	0.5~13.0	M14*P1.0	ER20	N20SGSX nano	W-FK05	4.40
○	BT50AD/B-SGER20SX-160	10	160	9	70	51	69.8	38	0.5~13.0	M14*P1.0	ER20	N20SGSX nano	W-FK05	4.80
	BT50AD/B-SGER20SX-200	10	200	9	110	51	69.8	38	0.5~13.0	M14*P1.0	ER20	N20SGSX nano	W-FK05	5.20
◎	BT50AD/B-SGER25SX-080	9	80	9	-	53	69.8	44	0.5~16.0	M18*P1.5	ER25	N25SGSX nano	W-FK06	4.40
◎	BT50AD/B-SGER25SX-100	9	100	9	-	53	69.8	44	0.5~16.0	M18*P1.5	ER25	N25SGSX nano	W-FK06	4.60
◎	BT50AD/B-SGER25SX-120	9	120	9	-	53	69.8	44	0.5~16.0	M18*P1.5	ER25	N25SGSX nano	W-FK06	4.80
○	BT50AD/B-SGER25SX-160	10	160	9	70	53	69.8	44	0.5~16.0	M18*P1.5	ER25	N25SGSX nano	W-FK06	5.20
	BT50AD/B-SGER25SX-200	10	200	9	110	53	69.8	44	0.5~16.0	M18*P1.5	ER25	N25SGSX nano	W-FK06	5.60
◎	BT50AD/B-SGER32SX-080	9	80	9	-	57	69.8	52	2.0~20.0	M24*P1.5	ER32	N32SGSX nano	W-FK08	4.50
◎	BT50AD/B-SGER32SX-100	9	100	9	-	57	69.8	52	2.0~20.0	M24*P1.5	ER32	N32SGSX nano	W-FK08	4.70
◎	BT50AD/B-SGER32SX-120	9	120	9	-	57	69.8	52	2.0~20.0	M24*P1.5	ER32	N32SGSX nano	W-FK08	4.90
○	BT50AD/B-SGER32SX-160	10	160	9	70	57	69.8	52	2.0~20.0	M24*P1.5	ER32	N32SGSX nano	W-FK08	5.30
	BT50AD/B-SGER32SX-200	10	200	9	110	57	69.8	52	2.0~20.0	M24*P1.5	ER32	N32SGSX nano	W-FK08	5.70
◎	BT50AD/B-SGER40SX-080	9	80	9	-	67	69.8	62	3.0~26.0	M28*P1.5	ER40	N40SGSX nano	W-FK09	4.90
◎	BT50AD/B-SGER40SX-100	9	100	9	-	67	69.8	62	3.0~26.0	M28*P1.5	ER40	N40SGSX nano	W-FK09	5.10
◎	BT50AD/B-SGER40SX-120	9	120	9	-	67	69.8	62	3.0~26.0	M28*P1.5	ER40	N40SGSX nano	W-FK09	5.30
○	BT50AD/B-SGER40SX-160	9	160	9	-	67	69.8	62	3.0~26.0	M28*P1.5	ER40	N40SGSX nano	W-FK09	5.70
	BT50AD/B-SGER40SX-200	9	200	9	-	67	69.8	62	3.0~26.0	M28*P1.5	ER40	N40SGSX nano	W-FK09	6.10

產品FIG.9 & 10出貨附件為高速平衡奈米螺帽
 NxxSGSX nano*1pc // PRODUCTS IN FIG.9 & 10 EQUIP WITH BALANCED NANO NUT NxxSGSX nano*1pc
 STOCK ◎=標準在庫品 // STOCK ◉=regular stock | STOCK ○=少量在庫品 // STOCK ◌=few stock | STOCK無標示=接單生產品 // STOCK
 BLANK=on request
 ER筒夾和扳手是另購品 // ER COLLET AND WRENCH TO BE ORDERED SEPARATELY

BT-SGER

SGER power ER collet chucks

SGER 強力型 ER 筒夾刀桿

84

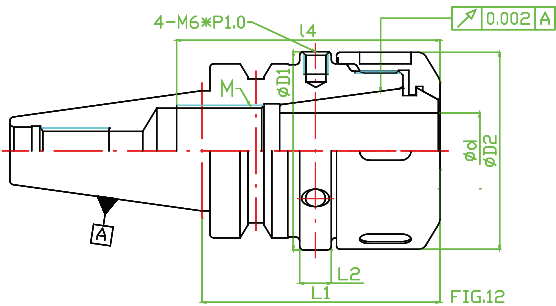
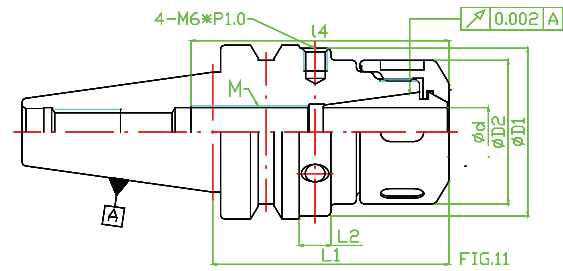

動平衡G2.5/25,000RPM可以另外施作 // BALANCE TO G2.5/25,000RPM IS AVAILABLE ON REQUEST

STOCK	CODE	FIG.	L1	L2	L3	L4	D1	D2	d	止動螺絲 (M) Screw Page 154	筒夾 COLLET Page 143	螺帽 NUT Page 151	扳手 WRENCH Page 154	重量 (KG) Weight
○	BT30GAD-SGER16SX-060	11	60	9	-	46	44.4	34	0.5~10.0	M11*P1.0	ER16	N16SGSX nano	W-FK04	0.60
	BT30GAD-SGER16SX-100	11	100	9	-	46	44.4	34	0.5~10.0	M11*P1.0	ER16	N16SGSX nano	W-FK04	0.80
○	BT30GAD-SGER20SX-060	11	60	9	-	51	44.4	38	0.5~13.0	M14*P1.0	ER20	N20SGSX nano	W-FK05	0.70
	BT30GAD-SGER20SX-100	11	100	9	-	51	44.4	38	0.5~13.0	M14*P1.0	ER20	N20SGSX nano	W-FK05	0.90
○	BT30GAD-SGER25SX-060	11	60	9	-	53	44.4	44	0.5~16.0	M18*P1.5	ER25	N25SGSX nano	W-FK06	0.90
	BT30GAD-SGER25SX-100	11	100	9	-	53	44.4	44	0.5~16.0	M18*P1.5	ER25	N25SGSX nano	W-FK06	1.30
○	BT30GAD-SGER32SX-060	12	60	8	-	47	52.4	52	2.0~20.0	M24*P1.5	ER32	N32SGSX nano	W-FK08	1.00
	BT30GAD-SGER32SX-100	12	100	8	-	57	52.4	52	2.0~20.0	M24*P1.5	ER32	N32SGSX nano	W-FK08	1.40

產品FIG.11 & 12出貨附件為高速平衡奈米螺帽

NxxSGSX nano*1pc // PRODUCTS IN FIG.11 & 12 EQUIP WITH BALANCED NANO NUT NxxSGSX nano*1pc

STOCK ◎=標準在庫品 // STOCK ○=regular stock | STOCK ○=少量在庫品 // STOCK ○=few stock | STOCK無標示=接單生產 // STOCK

BLANK=on request

ER筒夾和扳手是另購品 // ER COLLET AND WRENCH TO BE ORDERED SEPARATELY

ERM nut collet chucks & ER collet chucks

ERM 型螺帽筒夾刀桿 & ER 筒夾刀桿

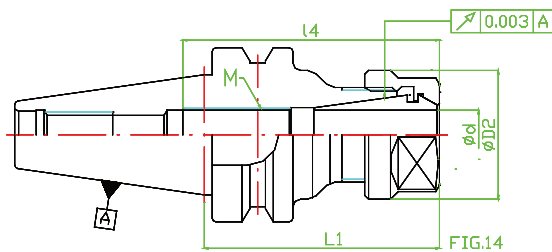
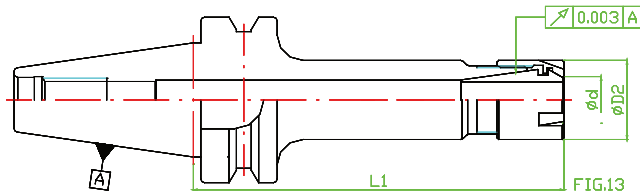

動平衡G2.5/25,000RPM可以另外施作 // BALANCE TO G2.5/25,000RPM IS AVAILABLE ON REQUEST

STOCK	CODE	FIG.	L1	L2	L3	I4	D1	D2	d	止動螺絲 (M) Screw Page 154	筒夾 COLLET Page 143	螺帽 NUT Page 151	扳手 WRENCH Page 154	重量 (KG) Weight
	BT30AD-ER11M-060	13	60	-	-	-	-	16	0.5~7.0	-	ER16	N11MX nano	W-ER11M	0.40
○	BT30AD-ER11M-100	13	100	-	-	-	-	16	0.5~7.0	-	ER16	N11MX nano	W-ER11M	0.60
	BT30AD-ER16M-060	13	60	-	-	-	-	22	0.5~10.0	-	ER16	N16MX nano	W-ER16M	0.50
○	BT30AD-ER16M-100	13	100	-	-	-	-	22	0.5~10.0	-	ER16	N16MX nano	W-ER16M	0.70
	BT30AD-ER20M-060	13	60	-	-	-	-	28	0.5~13.0	-	ER20	N20MX nano	W-ER20M	0.60
	BT30AD-ER20M-100	13	100	-	-	-	-	28	0.5~13.0	-	ER20	N20MX nano	W-ER20M	0.80
	BT30AD-ER25M-060	13	60	-	-	-	-	35	0.5~16.0	-	ER25	N25MX nano	W-ER25M	0.80
	BT30AD-ER25M-100	13	100	-	-	-	-	35	0.5~16.0	-	ER25	N25MX nano	W-ER25M	1.20
◎	BT30AD-ER11-060	14	60	-	-	32	-	19	0.5~7.0	M8*P1.0	ER16	N11SX nano	W-ER11	0.50
◎	BT30AD-ER11-100	14	100	-	-	32	-	19	0.5~7.0	M8*P1.0	ER16	N11SX nano	W-ER11	0.70
◎	BT30AD-ER16-060	14	60	-	-	46	-	28	0.5~10.0	M11*P1.0	ER16	N16SX nano	W-ER16	0.60
◎	BT30AD-ER16-100	14	100	-	-	46	-	28	0.5~10.0	M11*P1.0	ER16	N16SX nano	W-ER16	0.80
◎	BT30AD-ER20-060	14	60	-	-	51	-	34	0.5~13.0	M14*P1.0	ER20	N20SX nano	W-ER20	0.70
◎	BT30AD-ER20-100	14	100	-	-	51	-	34	0.5~13.0	M14*P1.0	ER20	N20SX nano	W-ER20	0.90
◎	BT30AD-ER25-060	14	60	-	-	53	-	42	0.5~16.0	M18*P1.5	ER25	N25SX nano	W-FK06	0.90
◎	BT30AD-ER25-100	14	100	-	-	53	-	42	0.5~16.0	M18*P1.5	ER25	N25SX nano	W-FK06	1.30
◎	BT30AD-ER32-060	14	60	-	-	47	-	50	2.0~20.0	M24*P1.5	ER32	N32SX nano	W-FK08	1.00
◎	BT30AD-ER32-100	14	100	-	-	57	-	50	2.0~20.0	M24*P1.5	ER32	N32SX nano	W-FK08	1.40

產品 FIG. 13 出貨附件為高速平衡奈米螺帽 NxxMX nano*1pc // PRODUCTS IN FIG.13 EQUIP WITH BALANCED NANO NUT NxxMX nano*1pc

產品 FIG. 14 出貨附件為高速平衡奈米螺帽 NxxSX nano*1pc // PRODUCTS IN FIG.14 EQUIP WITH BALANCED NANO NUT NxxSX nano*1pc

STOCK ◎=標準在庫品 // STOCK ○=regular stock | STOCK ○=少量在庫品 // STOCK ○=few stock | STOCK 無標示=接單生產品 // STOCK

BLANK=on request

ER 筒夾和扳手是另購品 // ER COLLET AND WRENCH TO BE ORDERED SEPARATELY

BT-ERM&ER

ERM nut collet chucks & ER collet chucks

ERM 型螺帽筒夾刀桿 & ER 筒夾刀桿

86

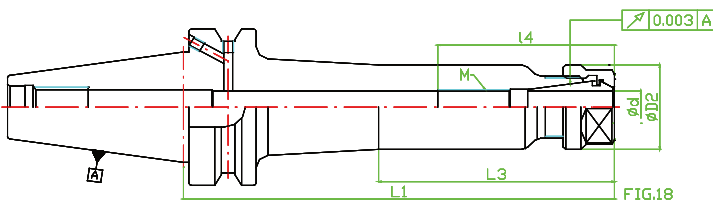
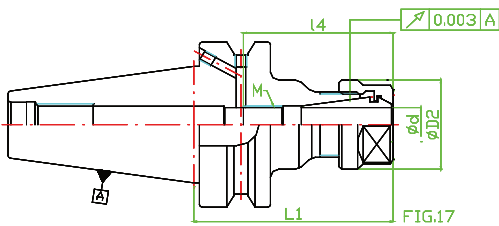
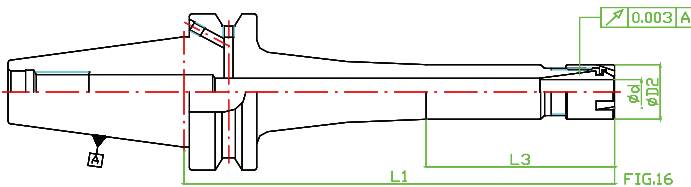
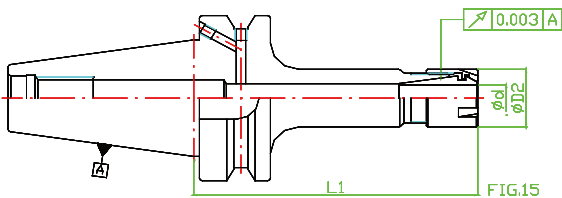

動平衡G2.5/25,000RPM可以另外施作 // BALANCE TO G2.5/25,000RPM IS AVAILABLE ON REQUEST

STOCK	CODE	FIG.	L1	L2	L3	L4	D1	D2	d	止動螺絲 (M) Screw Page 154	筒夾 COLLET Page 143	螺帽 NUT Page 151	扳手 WRENCH Page 154	重量 (KG) Weight
◎	BT40AD/B-ER11M-100	15	100	-	-	-	-	16	0.5~7.0	-	ER16	N11MX nano	W-ER11M	1.20
○	BT40AD/B-ER11M-160	15	160	-	-	-	-	16	0.5~7.0	-	ER16	N11MX nano	W-ER11M	1.70
◎	BT40AD/B-ER16M-100	15	100	-	-	-	-	22	0.5~10.0	-	ER16	N16MX nano	W-ER16M	1.30
○	BT40AD/B-ER16M-160	16	160	-	70	-	36	22	0.5~10.0	-	ER16	N16MX nano	W-ER16M	1.80
	BT40AD/B-ER20M-100	15	100	-	-	-	-	28	0.5~13.0	-	ER20	N20MX nano	W-ER20M	1.40
	BT40AD/B-ER20M-160	16	160	-	70	-	42	28	0.5~13.0	-	ER20	N20MX nano	W-ER20M	1.90
	BT40AD/B-ER25M-100	15	100	-	-	-	-	35	0.5~16.0	-	ER25	N25MX nano	W-ER25M	1.70
	BT40AD/B-ER25M-160	16	160	-	70	-	45	35	0.5~16.0	-	ER25	N25MX nano	W-ER25M	2.30

產品FIG.15 & 16出貨附件為高速平衡奈米螺帽

NxxMX nano*1pc // PRODUCTS IN FIG.15 & 16 EQUIP WITH BALANCED NANO NUT NxxMX nano*1pc

產品FIG.17 & 18出貨附件為高速平衡奈米螺帽

NxxSX nano*1pc // PRODUCTS IN FIG.17 & 18 EQUIP WITH BALANCED NANO NUT NxxSX nano*1pc

STOCK ◎=標準在庫品 // STOCK ○=regular stock | STOCK ○=少量在庫品 // STOCK ○=few stock | STOCK無標示=接單生產產品 // STOCK

BLANK=on request

ER筒夾和扳手是另購品 // ER COLLET AND WRENCH TO BE ORDERED SEPARATELY

ERM nut collet chucks & ER collet chucks

ERM 型螺帽筒夾刀桿 & ER 筒夾刀桿

動平衡G2.5/25,000RPM可以另外施作 // BALANCE TO G2.5/25,000RPM IS AVAILABLE ON REQUEST

STOCK	CODE	FIG.	L1	L2	L3	L4	D1	D2	d	止動螺絲 (M) Screw Page 154	筒夾 COLLET Page 143	螺帽 NUT Page 151	扳手 WRENCH Page 154	重量 (KG) Weight
◎	BT40AD/B-ER16-070	17	70	-	-	46	-	28	0.5~10.0	M11*P1.0	ER16	N16SX nano	W-ER16	1.20
◎	BT40AD/B-ER16-100	17	100	-	-	46	-	28	0.5~10.0	M11*P1.0	ER16	N16SX nano	W-ER16	1.40
○	BT40AD/B-ER16-120	17	120	-	-	46	-	28	0.5~10.0	M11*P1.0	ER16	N16SX nano	W-ER16	1.50
○	BT40AD/B-ER16-160	18	160	-	86	46	36	28	0.5~10.0	M11*P1.0	ER16	N16SX nano	W-ER16	1.90
	BT40AD/B-ER16-200	18	200	-	126	46	36	28	0.5~10.0	M11*P1.0	ER16	N16SX nano	W-ER16	2.30
◎	BT40AD/B-ER20-070	17	70	-	-	51	-	34	0.5~13.0	M14*P1.0	ER20	N20SX nano	W-ER20	1.30
◎	BT40AD/B-ER20-100	17	100	-	-	51	-	34	0.5~13.0	M14*P1.0	ER20	N20SX nano	W-ER20	1.50
○	BT40AD/B-ER20-120	17	120	-	-	51	-	34	0.5~13.0	M14*P1.0	ER20	N20SX nano	W-ER20	1.60
○	BT40AD/B-ER20-160	18	160	-	86	51	42	34	0.5~13.0	M14*P1.0	ER20	N20SX nano	W-ER20	2.00
	BT40AD/B-ER20-200	18	200	-	126	51	42	34	0.5~13.0	M14*P1.0	ER20	N20SX nano	W-ER20	2.40
◎	BT40AD/B-ER25-070	17	70	-	-	53	-	42	0.5~16.0	M18*P1.5	ER25	N25SX nano	W-FK06	1.50
◎	BT40AD/B-ER25-100	17	100	-	-	53	-	42	0.5~16.0	M18*P1.5	ER25	N25SX nano	W-FK06	1.80
○	BT40AD/B-ER25-120	17	120	-	-	53	-	42	0.5~16.0	M18*P1.5	ER25	N25SX nano	W-FK06	2.00
○	BT40AD/B-ER25-160	17	160	-	-	53	-	42	0.5~16.0	M18*P1.5	ER25	N25SX nano	W-FK06	2.40
	BT40AD/B-ER25-200	17	200	-	-	53	-	42	0.5~16.0	M18*P1.5	ER25	N25SX nano	W-FK06	2.80
◎	BT40AD/B-ER32-070	17	70	-	-	57	-	50	2.0~20.0	M24*P1.5	ER32	N32SX nano	W-FK08	1.60
◎	BT40AD/B-ER32-100	17	100	-	-	57	-	50	2.0~20.0	M24*P1.5	ER32	N32SX nano	W-FK08	1.90
○	BT40AD/B-ER32-120	17	120	-	-	57	-	50	2.0~20.0	M24*P1.5	ER32	N32SX nano	W-FK08	2.10
○	BT40AD/B-ER32-160	17	160	-	-	57	-	50	2.0~20.0	M24*P1.5	ER32	N32SX nano	W-FK08	2.40
	BT40AD/B-ER32-200	17	200	-	-	57	-	50	2.0~20.0	M24*P1.5	ER32	N32SX nano	W-FK08	2.90
◎	BT40AD/B-ER40-070	17	70	-	-	62	-	63	3.0~26.0	M28*P1.5	ER40	N40SX nano	W-FK09	2.00
◎	BT40AD/B-ER40-100	17	100	-	-	67	-	63	3.0~26.0	M28*P1.5	ER40	N40SX nano	W-FK09	2.30
○	BT40AD/B-ER40-120	17	120	-	-	67	-	63	3.0~26.0	M28*P1.5	ER40	N40SX nano	W-FK09	2.60
○	BT40AD/B-ER40-160	17	160	-	-	67	-	63	3.0~26.0	M28*P1.5	ER40	N40SX nano	W-FK09	3.20
	BT40AD/B-ER40-200	17	200	-	-	67	-	63	3.0~26.0	M28*P1.5	ER40	N40SX nano	W-FK09	3.80
STOCK	CODE	FIG.	L1	L2	L3	L4	D1	D2	d	止動螺絲 (M) Screw Page 154	筒夾 COLLET Page 143	螺帽 NUT Page 151	扳手 WRENCH Page 154	重量 (KG) Weight
	BT50AD/B-ER16-070	17	70	-	-	46	-	28	0.5~10.0	M11*P1.0	ER16	N16SX nano	W-ER16	4.10
	BT50AD/B-ER16-100	17	100	-	-	46	-	28	0.5~10.0	M11*P1.0	ER16	N16SX nano	W-ER16	4.20
	BT50AD/B-ER16-120	17	120	-	-	46	-	28	0.5~10.0	M11*P1.0	ER16	N16SX nano	W-ER16	4.30
	BT50AD/B-ER16-160	18	160	-	70	46	40	28	0.5~10.0	M11*P1.0	ER16	N16SX nano	W-ER16	4.70
	BT50AD/B-ER16-200	18	200	-	110	46	40	28	0.5~10.0	M11*P1.0	ER16	N16SX nano	W-ER16	5.10
	BT50AD/B-ER20-070	17	70	-	-	51	-	34	0.5~13.0	M14*P1.0	ER20	N20SX nano	W-ER20	4.20
	BT50AD/B-ER20-100	17	100	-	-	51	-	34	0.5~13.0	M14*P1.0	ER20	N20SX nano	W-ER20	4.30
	BT50AD/B-ER20-120	17	120	-	-	51	-	34	0.5~13.0	M14*P1.0	ER20	N20SX nano	W-ER20	4.40
	BT50AD/B-ER20-160	18	160	-	70	51	46	34	0.5~13.0	M14*P1.0	ER20	N20SX nano	W-ER20	4.80
	BT50AD/B-ER20-200	18	200	-	110	51	46	34	0.5~13.0	M14*P1.0	ER20	N20SX nano	W-ER20	5.20
	BT50AD/B-ER25-070	17	70	-	-	53	-	42	0.5~16.0	M18*P1.5	ER25	N25SX nano	W-FK06	4.40
	BT50AD/B-ER25-100	17	100	-	-	53	-	42	0.5~16.0	M18*P1.5	ER25	N25SX nano	W-FK06	4.60
	BT50AD/B-ER25-120	17	120	-	-	53	-	42	0.5~16.0	M18*P1.5	ER25	N25SX nano	W-FK06	4.80
	BT50AD/B-ER25-160	18	160	-	70	53	50	42	0.5~16.0	M18*P1.5	ER25	N25SX nano	W-FK06	5.20
	BT50AD/B-ER25-200	18	200	-	110	53	50	42	0.5~16.0	M18*P1.5	ER25	N25SX nano	W-FK06	5.60
	BT50AD/B-ER32-070	17	70	-	-	57	-	50	2.0~20.0	M24*P1.5	ER32	N32SX nano	W-FK08	4.50
	BT50AD/B-ER32-100	17	100	-	-	57	-	50	2.0~20.0	M24*P1.5	ER32	N32SX nano	W-FK08	4.70
	BT50AD/B-ER32-120	17	120	-	-	57	-	50	2.0~20.0	M24*P1.5	ER32	N32SX nano	W-FK08	4.90
	BT50AD/B-ER32-160	18	160	-	70	57	54	50	2.0~20.0	M24*P1.5	ER32	N32SX nano	W-FK08	5.30
	BT50AD/B-ER32-200	18	200	-	110	57	54	50	2.0~20.0	M24*P1.5	ER32	N32SX nano	W-FK08	5.70
	BT50AD/B-ER40-080	17	80	-	-	67	-	63	3.0~26.0	M28*P1.5	ER40	N40SX nano	W-FK09	4.90
	BT50AD/B-ER40-100	17	100	-	-	67	-	63	3.0~26.0	M28*P1.5	ER40	N40SX nano	W-FK09	5.10
	BT50AD/B-ER40-120	17	120	-	-	67	-	63	3.0~26.0	M28*P1.5	ER40	N40SX nano	W-FK09	5.30
	BT50AD/B-ER40-160	17	160	-	-	67	-	63	3.0~26.0	M28*P1.5	ER40	N40SX nano	W-FK09	5.70
	BT50AD/B-ER40-200	17	200	-	-	67	-	63	3.0~26.0	M28*P1.5	ER40	N40SX nano	W-FK09	6.10

產品FIG. 15 & 16出貨附件為高速平衡奈米螺帽

NxxMX nano*1pc // PRODUCTS IN FIG.15 & 16 EQUIP WITH BALANCED NANO NUT NxxMX nano*1pc

產品FIG.17 & 18出貨附件為高速平衡奈米螺帽

NxxSX nano*1pc // PRODUCTS IN FIG.17 & 18 EQUIP WITH BALANCED NANO NUT NxxSX nano*1pc

STOCK ◎=標準在庫品 // STOCK ○=regular stock | STOCK ○=少量在庫品 // STOCK ○=few stock | STOCK無標示=接單生產品 // STOCK

BLANK=on request

ER筒夾和扳手是另購品 // ER COLLET AND WRENCH TO BE ORDERED SEPARATELY

BT-ERM&ER

ERM nut collet chucks & ER collet chucks

ERM 型螺帽筒夾刀桿 & ER 筒夾刀桿

88

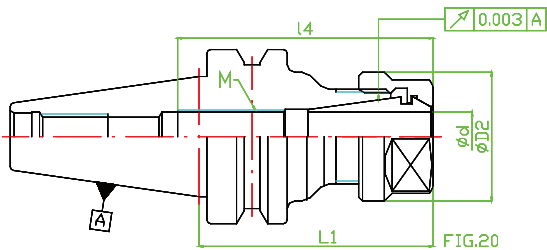
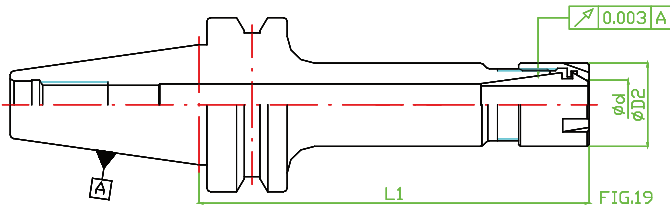

動平衡G2.5/25,000RPM可以另外施作 // BALANCE TO G2.5/25,000RPM IS AVAILABLE ON REQUEST

STOCK	CODE	FIG.	L1	L2	L3	L4	D1	D2	d	止動螺絲 (M) Screw Page 154	筒夾 COLLET Page 143	螺帽 NUT Page 151	扳手 WRENCH Page 154	重量 (KG) Weight
	BT30GAD-ER11M-060	19	60	-	-	-	-	16	0.5~7.0	-	ER16	N11MX nano	W-ER11M	0.40
○	BT30GAD-ER11M-100	19	100	-	-	-	-	16	0.5~7.0	-	ER16	N11MX nano	W-ER11M	0.60
	BT30GAD-ER16M-060	19	60	-	-	-	-	22	0.5~10.0	-	ER16	N16MX nano	W-ER16M	0.50
○	BT30GAD-ER16M-100	19	100	-	-	-	-	22	0.5~10.0	-	ER16	N16MX nano	W-ER16M	0.70
	BT30GAD-ER20M-060	19	60	-	-	-	-	28	0.5~13.0	-	ER20	N20MX nano	W-ER20M	0.60
	BT30GAD-ER20M-100	19	100	-	-	-	-	28	0.5~13.0	-	ER20	N20MX nano	W-ER20M	0.80
	BT30GAD-ER25M-060	19	60	-	-	-	-	35	0.5~16.0	-	ER25	N25MX nano	W-ER25M	0.80
	BT30GAD-ER25M-100	19	100	-	-	-	-	35	0.5~16.0	-	ER25	N25MX nano	W-ER25M	1.20
○	BT30GAD-ER11-060	20	60	-	-	32	-	19	0.5~7.0	M8*P1.0	ER16	N11SX nano	W-ER11	0.50
	BT30GAD-ER11-100	20	100	-	-	32	-	19	0.5~7.0	M8*P1.0	ER16	N11SX nano	W-ER11	0.70
○	BT30GAD-ER16-060	20	60	-	-	46	-	28	0.5~10.0	M11*P1.0	ER16	N16SX nano	W-ER16	0.60
	BT30GAD-ER16-100	20	100	-	-	46	-	28	0.5~10.0	M11*P1.0	ER16	N16SX nano	W-ER16	0.80
○	BT30GAD-ER20-060	20	60	-	-	51	-	34	0.5~13.0	M14*P1.0	ER20	N20SX nano	W-ER20	0.70
	BT30GAD-ER20-100	20	100	-	-	51	-	34	0.5~13.0	M14*P1.0	ER20	N20SX nano	W-ER20	0.90
○	BT30GAD-ER25-060	20	60	-	-	53	-	42	0.5~16.0	M18*P1.5	ER25	N25SX nano	W-FK06	0.90
	BT30GAD-ER25-100	20	100	-	-	53	-	42	0.5~16.0	M18*P1.5	ER25	N25SX nano	W-FK06	1.30
○	BT30GAD-ER32-060	20	60	-	-	47	-	50	2.0~20.0	M24*P1.5	ER32	N32SX nano	W-FK08	1.00
	BT30GAD-ER32-100	20	100	-	-	57	-	50	2.0~20.0	M24*P1.5	ER32	N32SX nano	W-FK08	1.40

產品FIG.19出貨附件為高速平衡奈米螺帽NxxMX nano*1pc // PRODUCTS IN FIG.19 EQUIP WITH BALANCED NANO NUT NxxMX nano*1pc

產品FIG.20出貨附件為高速平衡奈米螺帽NxxSX nano*1pc // PRODUCTS IN FIG.20 EQUIP WITH BALANCED NANO NUT NxxSX nano*1pc

STOCK ○=標準在庫品 // STOCK ○=regular stock | STOCK ○=少量在庫品 // STOCK ○=few stock | STOCK無標示=接單生產品 // STOCK

BLANK=on request

ER筒夾和扳手是另購品 // ER COLLET AND WRENCH TO BE ORDERED SEPARATELY